

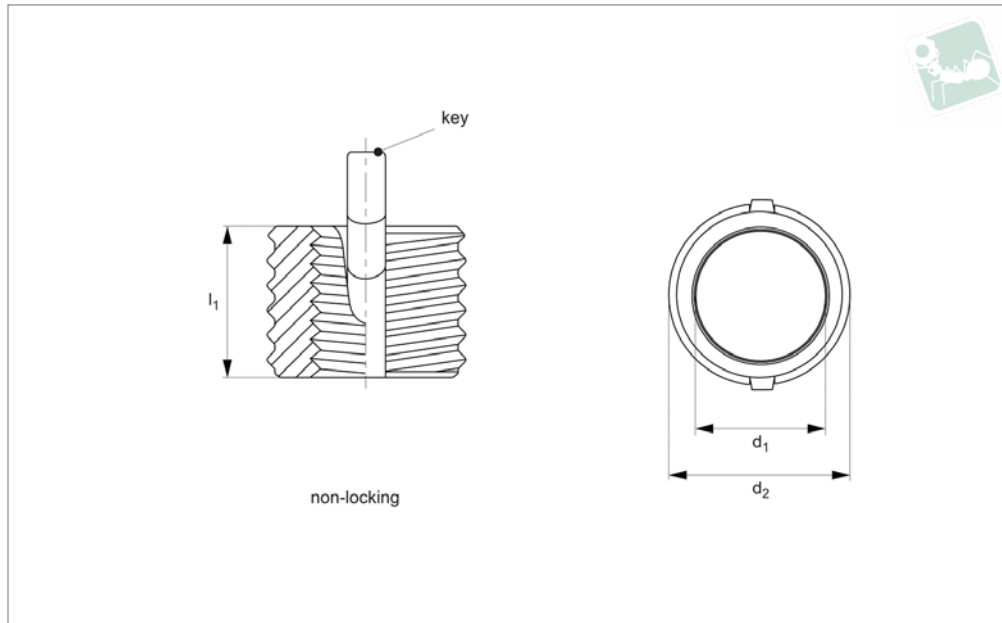

Threaded Insert MS/NAS - Mini - 4140 steel - non-locking - MS/NAS grade



Threaded
Inserts Steel



TR1606

THREADED INSERTS STEEL

Material

Inserts - 4140 alloy steel (160 KSI Min).
Keys - 302 CRES.
Cadmium plate (QQ-P-416 Type II, Cl. 2).
Dry film lubrication on self-locking inserts only.

Technical Notes

All dimensions in millimetres.
Internal threads: to Fed. Std. H28/21, MJ Form

General tolerances -

+/- 0,25mm, unless specified.
Tap drill hole tolerances -
6,9 to 10,8 = +0,100/-0,025
12,8 and over = +0,130/-0,025
NL = Non-Locking type.

Tips

Order installation tool separately, as identified by „Inst. Tool ref.“ in table.

Important Notes

Four locking keys on internal threads M6 and over. Two locking keys on internal threads smaller than M6.
Installation (Inst.) drill size, counter sink, thread tap and thread depth as specified in table.
Removal (Rem.) drill size and drill depth as specified in table.
Perform to standards: NA0148

Order No.	Type	d ₁ tol. 4H 6H	Thread type d ₁	d ₂ tol. 4h	Thread type d ₂	l ₁	Inst. c'sink hole size +0.25 - 0.00	Inst. tap drill size +0.080 -0.025	Inst. thread tap tol. 6H	Inst. thread tap depth min.	Inst. tool ref. TR1710	Removal drill size	Removal drill depth
TR1606.80382	NL	M 2x0,4	Coarse	M 4x0,7	Coarse	3,00	4,1	3,4	M 4x0,7	4,0	.0820	2,8	2,00
TR1606.80383	NL	M2,5x0,45	Coarse	M4,5x0,75	Coarse	3,81	4,6	3,9	M4,5x0,75	5,0	.0830	3,0	2,00
TR1606.80384	NL	M 3x0,5	Coarse	M 5x0,8	Coarse	4,25	5,1	4,4	M 5x0,8	5,5	.0840	3,5	2,25
TR1606.80386	NL	M 4x0,7	Coarse	M 6x0,75	Fine	5,25	6,1	5,5	M 6x0,75	6,5	.0860	4,6	2,50



TR1607

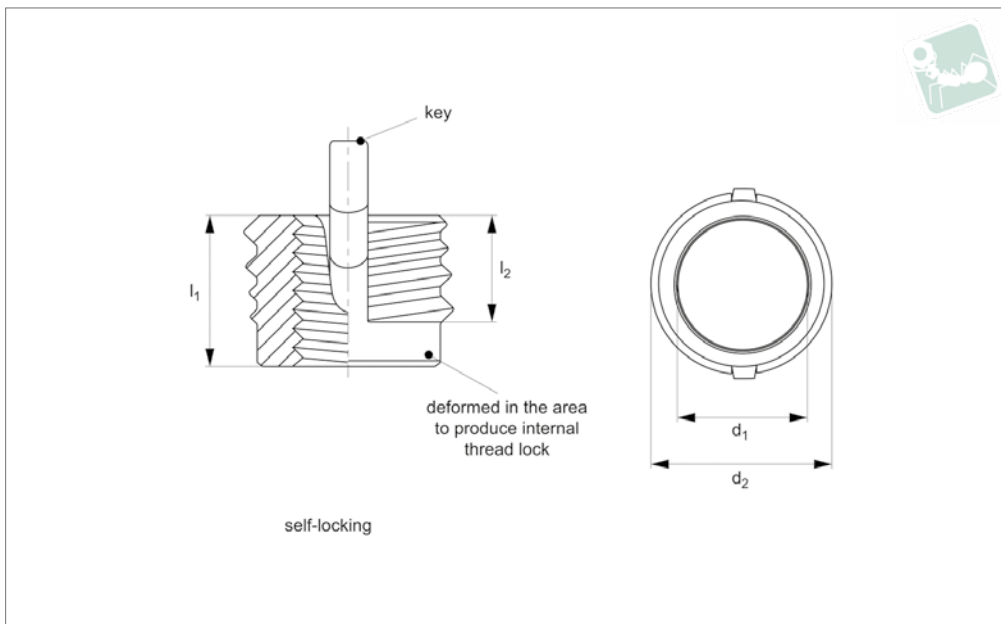

Material

Inserts - 4140 alloy steel (160 KSI Min).
Keys - 302 CRES.
Cadmium plate (QQ-P-416 Type II, Cl. 2).
Dry film lubrication on self-locking inserts only.

Technical Notes

All dimensions in millimetres.
Internal threads: to Fed. Std. H28/21, MJ Form
General tolerances -

+/- 0,25mm, unless specified.

Tap drill hole tolerances -
6,9 to 10,8 = +0,100/-0,025
12,8 and over = +0,130/-0,025

SL = Self-Locking type, deliberate deformity in thread produces self-affect once installed (see technical diagram).

Tips

Order installation tool separately, as identified by „Inst. Tool ref.“ in table.

Important Notes

Four locking keys on internal threads M6 and over. Two locking keys on internal threads smaller than M6.

Installation (Inst.) drill size, counter sink, thread tap and thread depth as specified in table.

Removal (Rem.) drill size and drill depth as specified in table.

Perform to standards: NA0148

Order No.	Type	d ₁ tol. 4H 6H	Thread type d ₁	d ₂ tol. 4h	Thread type d ₂	l ₁	l ₂	Inst. c'sink hole size +0.25 - 0.00	Inst. tap drill size +0.080 -0.025	Inst. thread tap tol. 6H	Inst. thread tap depth min.	Inst. tool ref. TR1710	Removal drill size	Removal drill depth
TR1607.81382	SL	M 2x0,4	Coarse	M 4x0,7	Coarse	3,00	2,20	4,1	3,4	M 4x0,7	4,0	.0820	2,8	2,00
TR1607.81383	SL	M2,5x0,45	Coarse	M4,5x0,75	Coarse	3,81	2,70	4,6	3,9	M4,5x0,75	5,0	.0830	3,0	2,00
TR1607.81384	SL	M 3x0,5	Coarse	M 5x0,8	Coarse	4,25	3,10	5,1	4,4	M 5x0,8	5,5	.0840	3,5	2,25
TR1607.81386	SL	M 4x0,7	Coarse	M 6x0,75	Fine	5,25	4,11	6,1	5,5	M 6x0,75	6,5	.0860	4,6	2,50



Threaded Insert MS/NAS - Mini - Inch

4140 steel - non-locking - MS/NAS grade



Threaded Inserts Steel

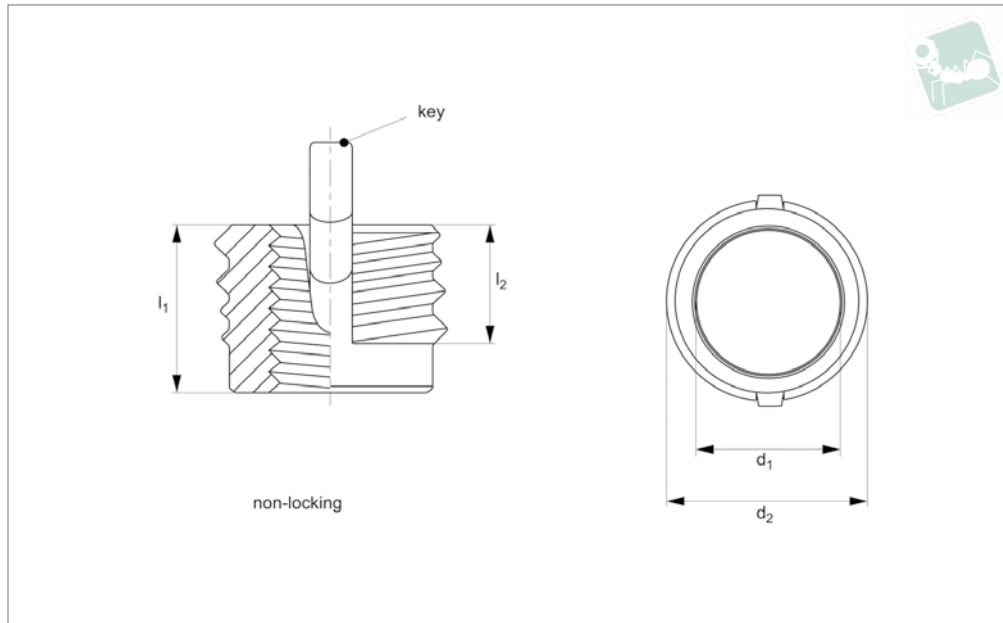

TR1660

THREADED INSERTS STEEL

Material

Inserts - 4140 alloy steel (160 KSI Min).
Keys - 302 CRES.
Cadmium plate (QQ-P-416 Type II, Cl. 2).
Dry film lubrication on self-locking inserts only.

Technical Notes

All dimensions in inches.
Internal threads: to SAE AS8879.
General tolerances -
+/- 0,010 unless specified.

Tap drill hole tolerances -

0,234 to 0,500 = +0,004/-0,001
0,500 and over = +0,005/-0,001
NL = Non-Locking type.

Tips

Order installation tool separately, as identified by „Inst. Tool ref.“ in table.

Important Notes

Four locking keys on internal threads 5/16 and over. Two locking keys on internal

threads smaller than 5/16.

Installation (Inst.) drill size, counter sink, thread tap and thread depth as specified in table.

Removal (Rem.) drill size and drill depth as specified in table.

Perform to standards: MIL-I-45914A (MS51830)

* Modified minor dia.

Order No.	Type	d ₁ class 3B	Thread type d ₁	d ₂ class 2A	Thread type d ₂	l ₁	l ₂ thread length	Inst. c'sink hole size +0.010 - 0.000	Inst. tap drill size +0.003 -0.001	Inst. thread depth min.	Inst. tap thread tap size class 2B	Inst. tool ref. TR1700	Removal drill size	Removal drill depth
TR1660.80283	NL	2-56	UNC	8-32	UNC	,120	,90	,166	,134	,140	8-32	.0830	#33	1/16
TR1660.80284	NL	4-40	UNC	10-32	UNF	,170	,125	,194	,161	,160	10-32	.0840	#29	3/32
TR1660.80285	NL	6-32	UNC	12-28	UNF	,170	,125	,220	,187	,160	2-28	.0850	#21	3/32
TR1660.80286	NL	8-32	UNC	1/4-28*	UNF	,220	,175	,255	,228	,210	1/4-28	.0860	# 8	1/8



TR1661

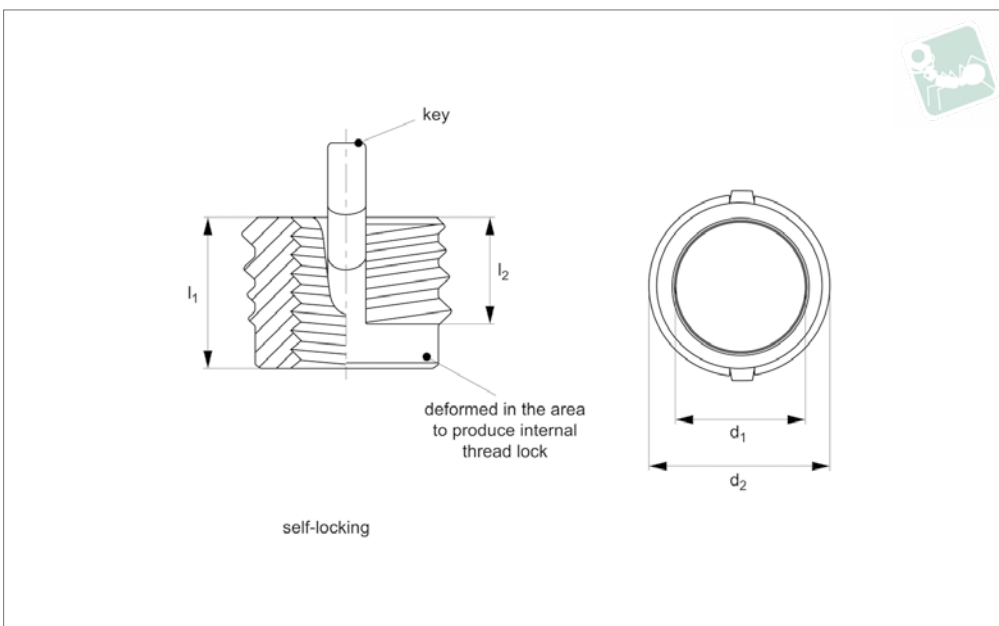

Material

Inserts - 4140 alloy steel (160 KSI Min).
Keys - 302 CRES.
Cadmium plate (QQ-P-416 Type II, Cl. 2).
Dry film lubrication on self-locking inserts only.

Technical Notes

All dimensions in inches.
Internal threads: to SAE AS8879.
General tolerances -
+/- 0,010 unless specified.

Tap drill hole tolerances -

0,234 to 0,500 = +0,004/-0,001
0,500 and over = +0,005/-0,001
SL = Self-Locking type, deliberate deformity in thread produces self-affect once installed (see technical diagram).

Tips

Order installation tool separately, as identified by „Inst. Tool ref.“ in table.

Important Notes

Four locking keys on internal threads 5/16 and over. Two locking keys on internal threads smaller than 5/16.
Installation (Inst.) drill size, counter sink, thread tap and thread depth as specified in table.
Removal (Rem.) drill size and drill depth as specified in table.
Perform to standards: MIL-I-45914A (MS51830)

Order No.	Type	d ₁ class 3B	Thread type d ₁	d ₂ class 2A	Thread type d ₂	l ₁	l ₂ thread length	Inst. c'sink hole size +0.010 - 0.000	Inst. tap drill size +0.003 -0.001	Inst. thread tap depth min.	Inst. thread tap size class 2B	Inst. tool ref. TR1700	Removal drill size	Removal drill depth
TR1661.81283	SL	2-56	UNC	8-32	UNC	,120	,90	,166	,134	,140	8-32	.0830	#33	1/16
TR1661.81284	SL	4-40	UNC	10-32	UNF	,170	,125	,194	,161	,160	10-32	.0840	#29	3/32
TR1661.81285	SL	6-32	UNC	12-28	UNF	,170	,125	,220	,187	,160	2-28	.0850	#21	3/32
TR1661.81286	SL	8-32	UNC	1/4-28*	UNF	,220	,175	,255	,228	,210	1/4-28	.0860	# 8	1/8