

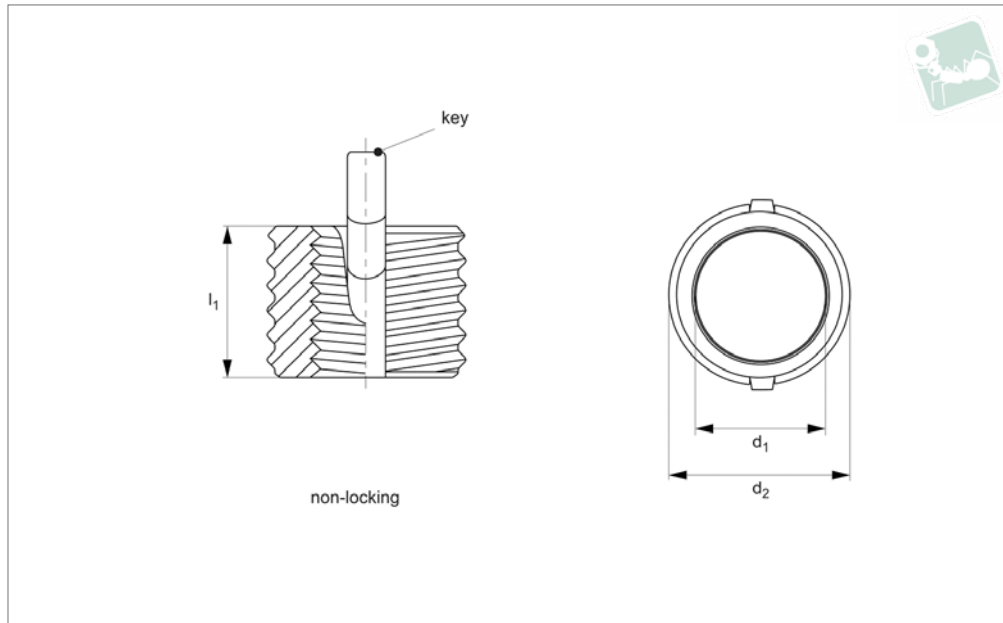

Threaded Insert MS/NAS - Mini - 4140 steel - non-locking - MS/NAS grade

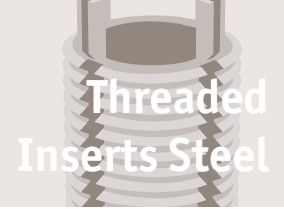

TR1606

THREADED INSERTS STEEL

Material

Inserts - 4140 alloy steel (160 KSI Min).
Keys - 302 CRES.
Cadmium plate (QQ-P-416 Type II, Cl. 2).
Dry film lubrication on self-locking inserts only.

Technical Notes

All dimensions in millimetres.
Internal threads: to Fed. Std. H28/21, MJ Form

General tolerances -

+/- 0,25mm, unless specified.
Tap drill hole tolerances -
6,9 to 10,8 = +0,100/-0,025
12,8 and over = +0,130/-0,025
NL = Non-Locking type.

Tips

Order installation tool separately, as identified by „Inst. Tool ref.“ in table.

Important Notes

Four locking keys on internal threads M6 and over. Two locking keys on internal threads smaller than M6.
Installation (Inst.) drill size, counter sink, thread tap and thread depth as specified in table.
Removal (Rem.) drill size and drill depth as specified in table.
Perform to standards: NA0148

Order No.	Type	d ₁ tol. 4H 6H	Thread type d ₁	d ₂ tol. 4h	Thread type d ₂	l ₁	Inst. c'sink hole size +0.25 - 0.00	Inst. tap drill size +0.080 -0.025	Inst. thread tap tol. 6H	Inst. thread tap depth min.	Inst. tool ref. TR1710	Removal drill size	Removal drill depth
TR1606.80382	NL	M 2x0,4	Coarse	M 4x0,7	Coarse	3,00	4,1	3,4	M 4x0,7	4,0	.0820	2,8	2,00
TR1606.80383	NL	M2,5x0,45	Coarse	M4,5x0,75	Coarse	3,81	4,6	3,9	M4,5x0,75	5,0	.0830	3,0	2,00
TR1606.80384	NL	M 3x0,5	Coarse	M 5x0,8	Coarse	4,25	5,1	4,4	M 5x0,8	5,5	.0840	3,5	2,25
TR1606.80386	NL	M 4x0,7	Coarse	M 6x0,75	Fine	5,25	6,1	5,5	M 6x0,75	6,5	.0860	4,6	2,50



TR1607

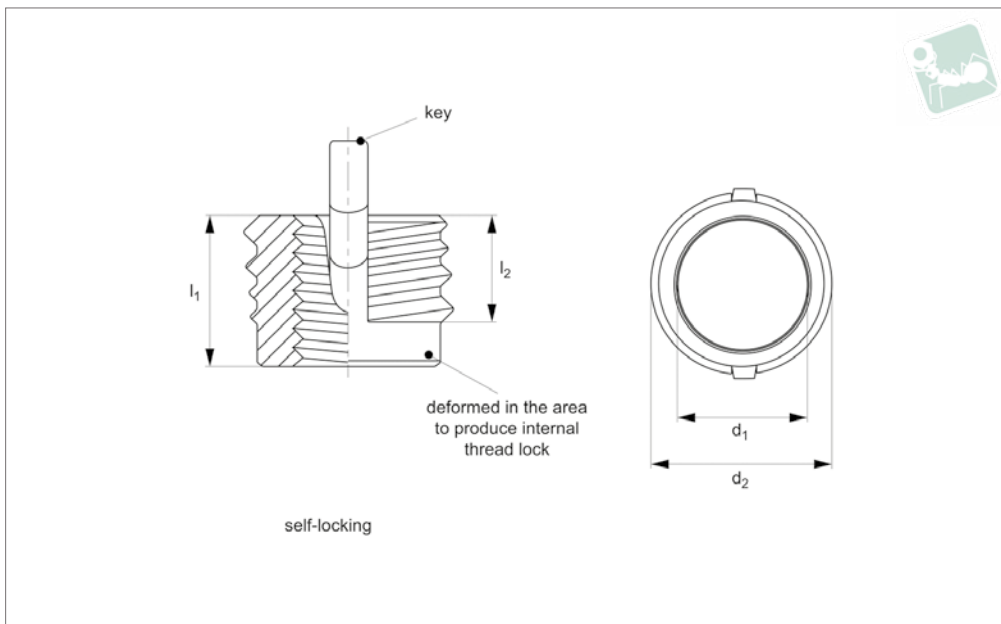

Material

Inserts - 4140 alloy steel (160 KSI Min).
Keys - 302 CRES.
Cadmium plate (QQ-P-416 Type II, Cl. 2).
Dry film lubrication on self-locking inserts only.

Technical Notes

All dimensions in millimetres.
Internal threads: to Fed. Std. H28/21, MJ Form
General tolerances -

+/- 0,25mm, unless specified.

Tap drill hole tolerances -
6,9 to 10,8 = +0,100/-0,025
12,8 and over = +0,130/-0,025

SL = Self-Locking type, deliberate deformity in thread produces self-affect once installed (see technical diagram).

Tips

Order installation tool separately, as identified by „Inst. Tool ref.“ in table.

Important Notes

Four locking keys on internal threads M6 and over. Two locking keys on internal threads smaller than M6.

Installation (Inst.) drill size, counter sink, thread tap and thread depth as specified in table.

Removal (Rem.) drill size and drill depth as specified in table.

Perform to standards: NA0148

Order No.	Type	d ₁ tol. 4H 6H	Thread type d ₁	d ₂ tol. 4h	Thread type d ₂	l ₁	l ₂	Inst. c'sink hole size +0.25 - 0.00	Inst. tap drill size +0.080 -0.025	Inst. thread tap tol. 6H	Inst. thread tap depth min.	Inst. tool ref. TR1710	Removal drill size	Removal drill depth
TR1607.81382	SL	M 2x0,4	Coarse	M 4x0,7	Coarse	3,00	2,20	4,1	3,4	M 4x0,7	4,0	.0820	2,8	2,00
TR1607.81383	SL	M2,5x0,45	Coarse	M4,5x0,75	Coarse	3,81	2,70	4,6	3,9	M4,5x0,75	5,0	.0830	3,0	2,00
TR1607.81384	SL	M 3x0,5	Coarse	M 5x0,8	Coarse	4,25	3,10	5,1	4,4	M 5x0,8	5,5	.0840	3,5	2,25
TR1607.81386	SL	M 4x0,7	Coarse	M 6x0,75	Fine	5,25	4,11	6,1	5,5	M 6x0,75	6,5	.0860	4,6	2,50



Threaded Insert MS/NAS - Mini - Inch

4140 steel - non-locking - MS/NAS grade

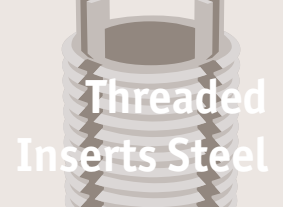

Threaded Inserts Steel

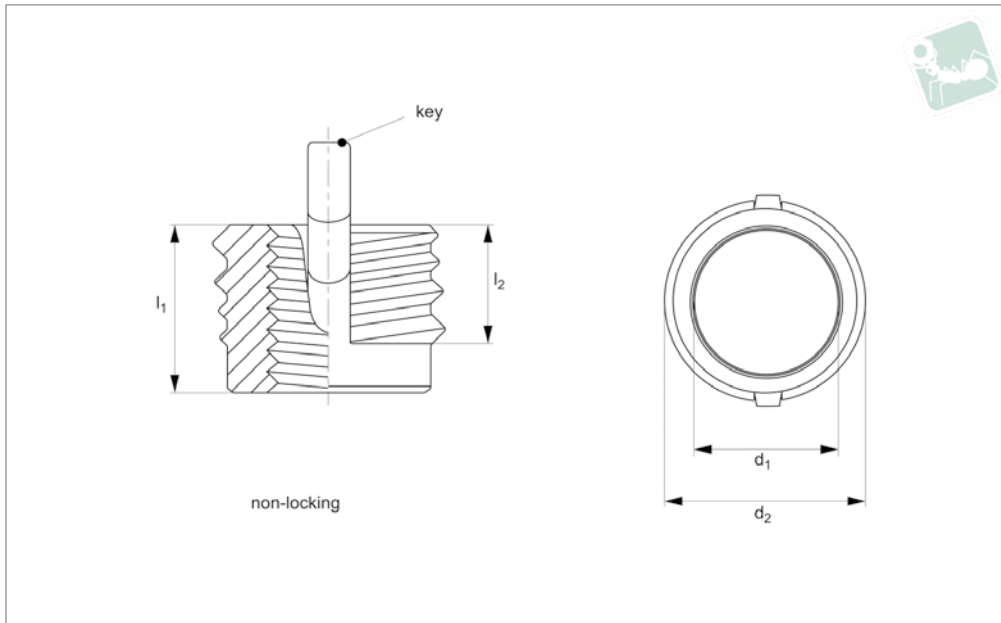

TR1660

THREADED INSERTS STEEL

Material

Inserts - 4140 alloy steel (160 KSI Min).
Keys - 302 CRES.
Cadmium plate (QQ-P-416 Type II, Cl. 2).
Dry film lubrication on self-locking inserts only.

Technical Notes

All dimensions in inches.
Internal threads: to SAE AS8879.
General tolerances -
+/- 0,010 unless specified.

Tap drill hole tolerances -

0,234 to 0,500 = +0,004/-0,001
0,500 and over = +0,005/-0,001
NL = Non-Locking type.

Tips

Order installation tool separately, as identified by „Inst. Tool ref.“ in table.

Important Notes

Four locking keys on internal threads 5/16 and over. Two locking keys on internal

threads smaller than 5/16.

Installation (Inst.) drill size, counter sink, thread tap and thread depth as specified in table.

Removal (Rem.) drill size and drill depth as specified in table.

Perform to standards: MIL-I-45914A (MS51830)

* Modified minor dia.

Order No.	Type	d ₁ class 3B	Thread type d ₁	d ₂ class 2A	Thread type d ₂	l ₁	l ₂ thread length	Inst. c'sink hole size +0.010 - 0.000	Inst. tap drill size +0.003 -0.001	Inst. thread depth min.	Inst. tap thread tap size class 2B	Inst. tool ref. TR1700	Removal drill size	Removal drill depth
TR1660.80283	NL	2-56	UNC	8-32	UNC	,120	,90	,166	,134	,140	8-32	.0830	#33	1/16
TR1660.80284	NL	4-40	UNC	10-32	UNF	,170	,125	,194	,161	,160	10-32	.0840	#29	3/32
TR1660.80285	NL	6-32	UNC	12-28	UNF	,170	,125	,220	,187	,160	2-28	.0850	#21	3/32
TR1660.80286	NL	8-32	UNC	1/4-28*	UNF	,220	,175	,255	,228	,210	1/4-28	.0860	# 8	1/8



TR1661

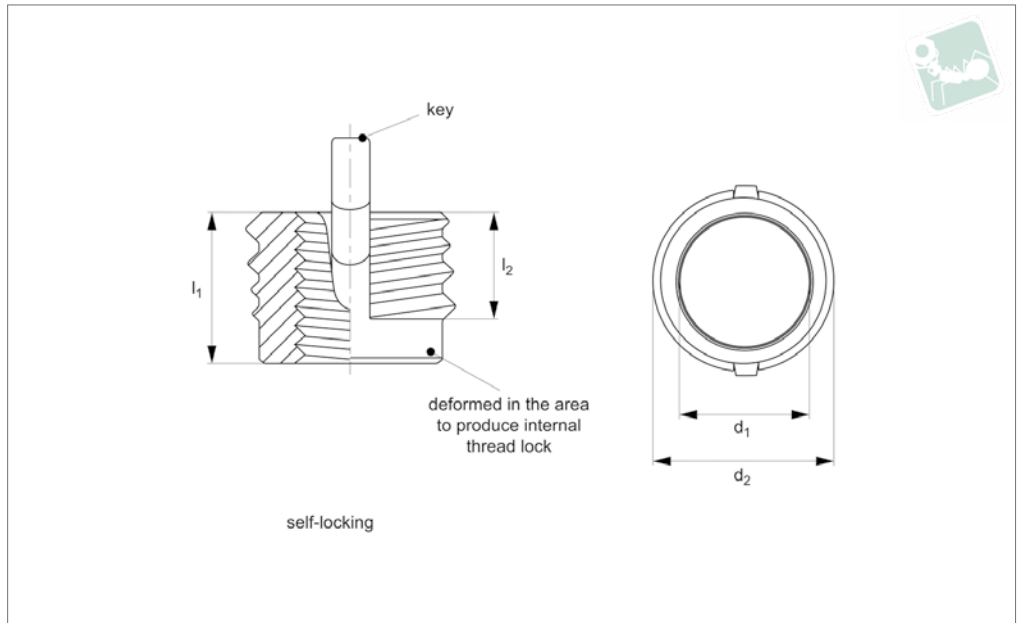

Material

Inserts - 4140 alloy steel (160 KSI Min).
 Keys - 302 CRES.
 Cadmium plate (QQ-P-416 Type II, Cl. 2).
 Dry film lubrication on self-locking inserts only.

Technical Notes

All dimensions in inches.
 Internal threads: to SAE AS8879.
 General tolerances -
 +/- 0,010 unless specified.

Tap drill hole tolerances -

0,234 to 0,500 = +0,004/-0,001
 0,500 and over = +0,005/-0,001
SL = Self-Locking type, deliberate deformity in thread produces self-affect once installed (see technical diagram).

Tips

Order installation tool separately, as identified by „Inst. Tool ref.“ in table.

Important Notes

Four locking keys on internal threads 5/16 and over. Two locking keys on internal threads smaller than 5/16.
 Installation (Inst.) drill size, counter sink, thread tap and thread depth as specified in table.
 Removal (Rem.) drill size and drill depth as specified in table.
 Perform to standards: MIL-I-45914A (MS51830)

Order No.	Type	d ₁ class 3B	Thread type d ₁	d ₂ class 2A	Thread type d ₂	l ₁	l ₂ thread length	Inst. c'sink hole size +0.010 - 0.000	Inst. tap drill size +0.003 -0.001	Inst. thread tap depth min.	Inst. thread tap size class 2B	Inst. tool ref. TR1700	Removal drill size	Removal drill depth
TR1661.81283	SL	2-56	UNC	8-32	UNC	,120	,90	,166	,134	,140	8-32	.0830	#33	1/16
TR1661.81284	SL	4-40	UNC	10-32	UNF	,170	,125	,194	,161	,160	10-32	.0840	#29	3/32
TR1661.81285	SL	6-32	UNC	12-28	UNF	,170	,125	,220	,187	,160	2-28	.0850	#21	3/32
TR1661.81286	SL	8-32	UNC	1/4-28*	UNF	,220	,175	,255	,228	,210	1/4-28	.0860	# 8	1/8



Threaded Insert - Metric

thinwall - carbon steel

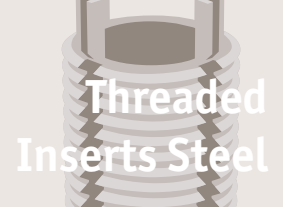

TR1520

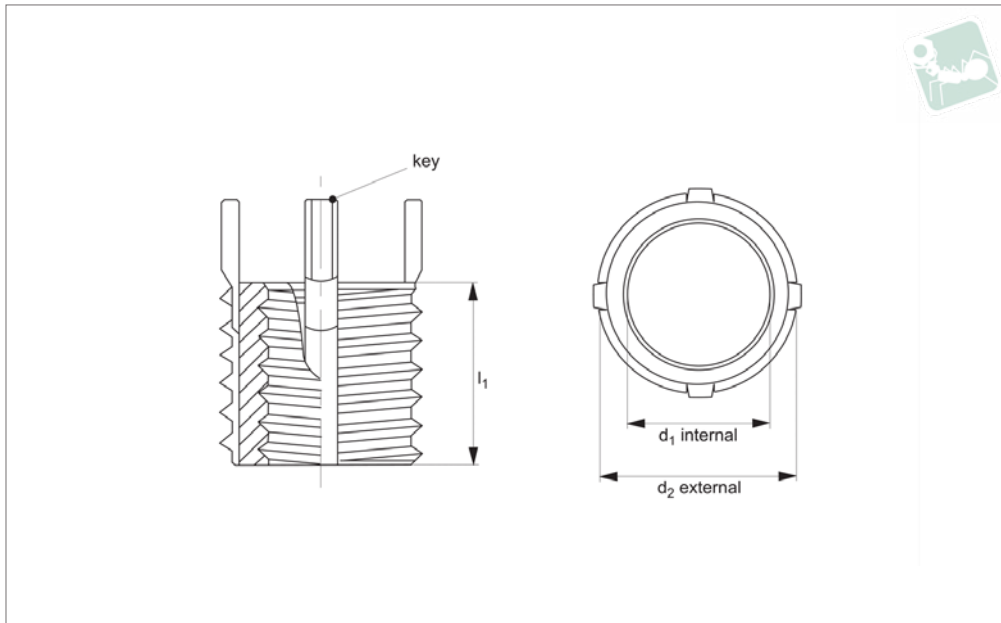

THREADED INSERTS STEEL

Material

Inserts: carbon steel (C1215) or equivalent. Zinc phosphate.
Keys: stainless steel (302 CRES) or equivalent. Passivated.

Technical Notes

General tolerances:
±0,25, unless specified.

Tap drill hole tolerances:

6,9 to 10,8 = +0,10/-0,025.
12,8 and over = +0,13/-0,025.

Tips

Order installation tool separately, as identified by „Inst. tool ref.“ in table.

Important Notes

Four locking keys on internal threads M 8 and over. Two locking keys on internal threads smaller than M 8.
Installation (Inst.) drill size, countersink, thread tap and thread depth as specified in table.
Removal drill size and drill depth as speci-

Order No.	Int. d ₁ tol. 6H	Int. thread type d ₁	Ext. d ₂ tol. 6g	Ext. thread type d ₂	l ₁	Inst. tap drill size	Inst. tool ref. 22060	Inst. c'sink dia. ±0.25 ±0	Inst. thread tap tol. 6H	Inst. thread depth min.	Removal drill size	Removal drill depth
TR1520.65951	M 5x0,80	Coarse	M 8x1,25	Coarse	8	6,9	.W0510	8,3	M 8x1,25	9,5	5,5	4,0
TR1520.65952	M 6x1,00	Coarse	M10x1,25	Fine	10	8,8	.W0520	10,3	M10x1,25	11,5	7,5	4,8
TR1520.65953	M 8x1,25	Coarse	M12x1,25	Fine	12	10,8	.W0530	12,3	M12x1,25	13,5	9,5	4,8
TR1520.65153	M 8x1,00	Fine	M12x1,25	Fine	12	10,8	.W0530	12,3	M12x1,25	13,5	9,5	4,8
TR1520.65955	M10x1,50	Coarse	M14x1,50	Fine	14	12,8	.W0550	14,3	M14x1,50	15,5	11,5	4,8
TR1520.65155	M10x1,25	Fine	M14x1,50	Fine	14	12,8	.W0550	14,3	M14x1,50	15,5	11,5	4,8
TR1520.65956	M12x1,75	Coarse	M16x1,50	Fine	16	14,8	.W0560	16,3	M16x1,50	17,5	13,5	4,8
TR1520.65156	M12x1,25	Fine	M16x1,50	Fine	16	14,8	.W0560	16,3	M16x1,50	17,5	13,5	4,8



TR1570

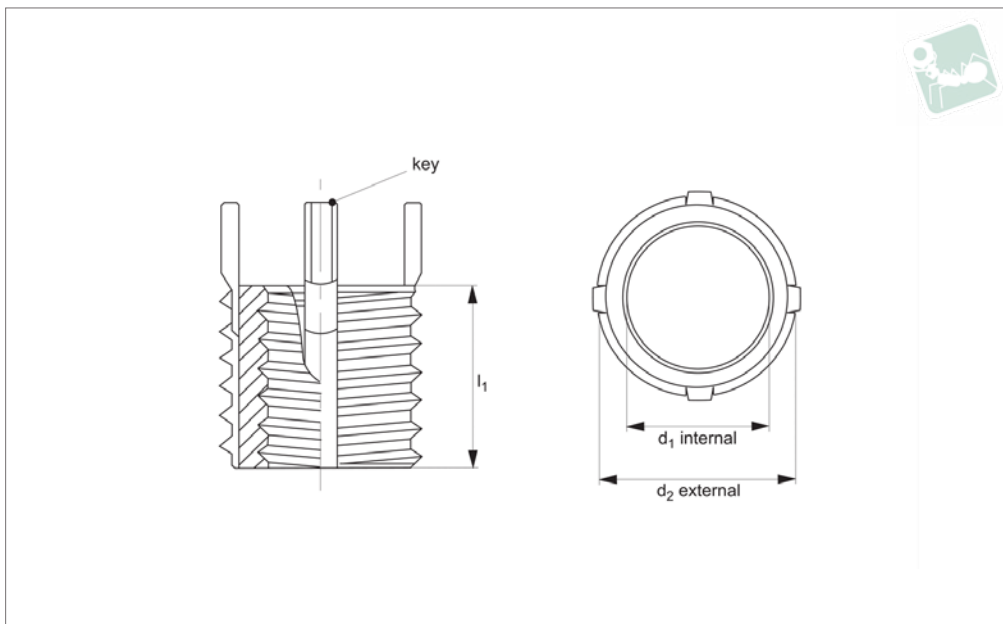

Material

Inserts: carbon steel (C1215) or equivalent. Zinc phosphate.

Keys: stainless steel (302 CRES) or equivalent. Passivated.

Technical Notes

General tolerances:

± 0,010" unless specified.

Tap drill hole tolerances:

0,234 to 0,500 = +0,004/-0,001"
0,500 and over = +0,005/-0,001"

Tips

Order installation tool separately, as identified by „Inst. tool ref.“ in table.

Important Notes

Four locking keys on internal threads 5/16" and over. Two locking keys on internal

threads smaller than 5/16".

Installation (Inst.) drill size, countersink, thread tap and thread depth as specified in table.

Removal drill size and drill depth as specified in table.

All dimensions in inches.

Order No.	Int. d ₁ tol. 2B	Int. thread type d ₁	Ext. d ₂ tol. 2A	Ext. thread type d ₂	l ₁	Inst. tap drill size	Inst. tool ref. 22054	Inst. c'sink dia. +0.010 - 0.000	Inst. thread tap tol. 2B	Inst. thread depth min.	Removal drill size	Removal drill depth
TR1570.65921	10-24	UNC	5/16"-18	UNC	0,31	17/64"	.W0210	0,32	5/16"-18	0,37	7/32"	1/8"
TR1570.66121	10-32	UNF	5/16"-18	UNC	0,31	17/64"	.W0210	0,32	5/16"-18	0,37	7/32"	1/8"
TR1570.65922	1/4"-20	UNC	3/8"-16	UNC	0,37	21/64"	.W0220	0,38	3/8"-16	0,43	9/32"	3/16"
TR1570.66122	1/4"-28	UNF	3/8"-16	UNC	0,37	21/64"	.W0220	0,38	3/8"-16	0,43	9/32"	3/16"
TR1570.65923	5/16"-18	UNC	7/16"-14	UNC	0,43	25/64"	.W0230	0,44	7/16"-14	0,50	11/32"	3/16"
TR1570.66123	5/16"-24	UNF	7/16"-14	UNC	0,43	25/64"	.W0230	0,44	7/16"-14	0,50	11/32"	3/16"
TR1570.65924	3/8"-16	UNC	1/2"-13	UNC	0,50	29/64"	.W0240	0,51	1/2"-13	0,56	13/32"	3/16"
TR1570.66124	3/8"-24	UNF	1/2"-13	UNC	0,50	29/64"	.W0240	0,51	1/2"-13	0,56	13/32"	3/16"
TR1570.65925	7/16"-14	UNC	9/16"-12	UNC	0,56	33/64"	.W0250	0,57	9/16"-12	0,62	15/32"	3/16"
TR1570.66125	7/16"-20	UNF	9/16"-12	UNC	0,56	33/64"	.W0250	0,57	9/16"-12	0,62	15/32"	3/16"
TR1570.65926	1/2"-13	UNC	5/8"-11	UNC	0,62	37/64"	.W0260	0,63	5/8"-11	0,68	17/32"	3/16"
TR1570.66126	1/2"-20	UNF	5/8"-11	UNC	0,62	37/64"	.W0260	0,63	5/8"-11	0,68	17/32"	3/16"



Threaded Insert MS/NAS - L Duty - 4140 steel - non-locking - MS/NAS grade

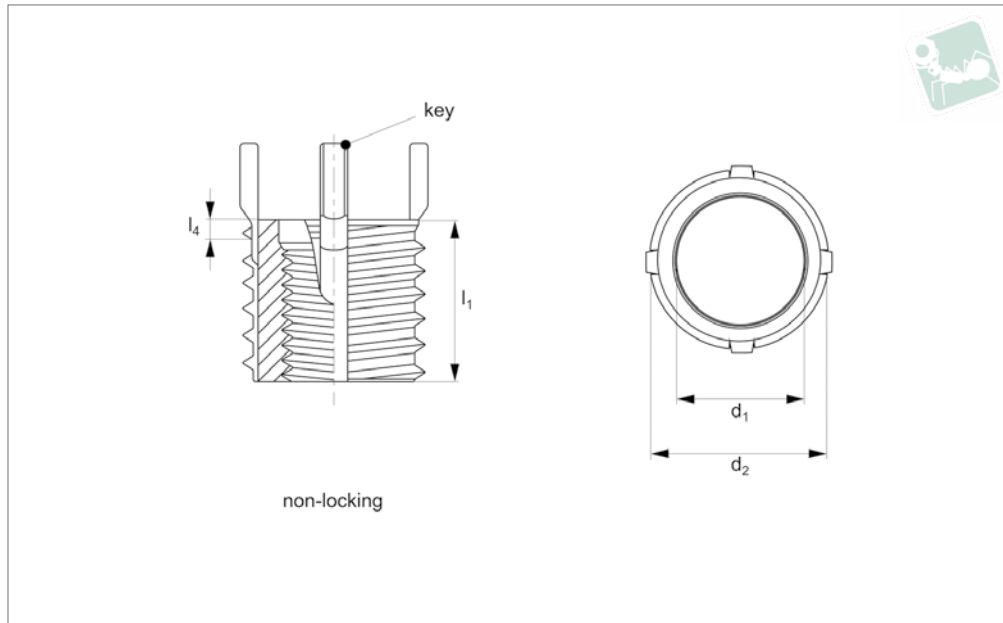
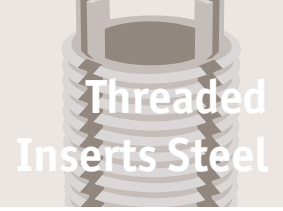

TR1608

THREADED INSERTS STEEL

Material

Inserts - 4140 alloy steel (160 KSI Min).
Keys - 302 CRES.
Cadmium plate (QQ-P-416 Type II, Cl. 2).
Dry film lubrication on self-locking inserts only.

Technical Notes

All dimensions in millimetres.
Internal threads: to Fed. Std. H28/21, MJ Form

General tolerances -

+/- 0,25mm, unless specified.
Tap drill hole tolerances -
6,9 to 10,8 = +0,100/-0,025
12,8 and over = +0,130/-0,025
NL = Non-Locking type.

Tips

Order installation tool separately, as identified by „Inst. Tool ref.“ in table.

Important Notes

Four locking keys on internal threads M 6 and over. Two locking keys on internal threads smaller than M 6.
Installation (Inst.) drill size, counter sink, thread tap and thread depth as specified in table.
Removal (Rem.) drill size and drill depth as specified in table.
Perform to standards: NA0148

Order No.	Type	d ₁ tol. 4H 5H	Thread type d ₁	d ₂ tol. 4h	Thread type d ₂	Inst. tap drill size	l ₁	l ₄ c'bore depth	C'sink hole size +0.25 - 0.00	Inst. thread tap tol. 6H	Inst. thread tap depth min.	Inst. tool ref. TI1712	Removal drill depth	Removal drill size
TR1608.80351	NL	M 5x0,8	Coarse	M 8x1,25	Coarse	6,90	8,0	1,27	8,25	M 8x1,25	9,5	.0510	4,00	5,50
TR1608.80551	NL	M 5x0,5	Fine	M 8x1,25	Coarse	6,90	8,0	1,27	8,25	M 8x1,25	9,5	.0510	4,00	5,50
TR1608.80352	NL	M 6x1,0	Coarse	M10x1,25	Fine	8,80	10,0	1,78	10,25	M10x1,25	11,5	.0520	4,75	7,50
TR1608.80552	NL	M 6x0,75	Fine	M10x1,25	Fine	8,80	10,0	1,78	10,25	M10x1,25	11,5	.0520	4,75	7,50
TR1608.80353	NL	M 8x1,25	Coarse	M12x1,25	Fine	10,80	12,0	1,78	12,25	M12x1,25	13,5	.0530	4,75	9,50
TR1608.80553	NL	M 8x1,0	Fine	M12x1,25	Fine	10,80	12,0	1,78	12,25	M12x1,25	13,5	.0530	4,75	9,50
TR1608.80355	NL	M10x1,5	Coarse	M14x1,5	Fine	12,80	14,0	2,29	14,25	M14x1,5	15,5	.0550	4,75	11,50
TR1608.80555	NL	M10x1,25	Fine	M14x1,5	Fine	12,80	14,0	2,29	14,25	M14x1,5	15,5	.0550	4,75	11,50
TR1608.80356	NL	M12x1,75	Coarse	M16x1,5	Fine	14,75	16,0	2,29	16,25	M16x1,5	17,5	.0560	4,75	13,50
TR1608.80556	NL	M12x1,25	Fine	M16x1,5	Fine	14,75	16,0	2,29	16,25	M16x1,5	17,5	.0560	4,75	13,50



TR1609

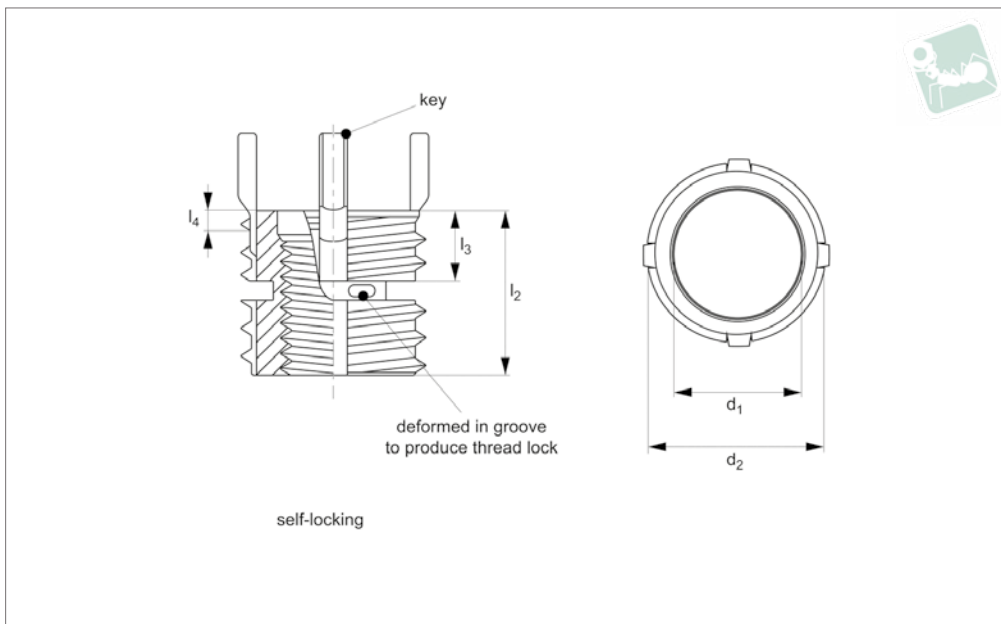

Material

Inserts - 4140 alloy steel (160 KSI Min).
 Keys - 302 CRES.
 Cadmium plate (QQ-P-416 Type II, Cl. 2).
 Dry film lubrication on self-locking inserts only.

Technical Notes

All dimensions in millimetres.
 Internal threads: to Fed. Std. H28/21, MJ Form
 General tolerances -

+/- 0,25mm, unless specified.

Tap drill hole tolerances -
 6,9 to 10,8 = +0,100/-0,025
 12,8 and over = +0,130/-0,025

SL = Self-Locking type, deliberate deformity in thread produces self-affect once installed (see technical diagram).

Tips

Order installation tool separately, as identified by „Inst. Tool ref.“ in table.

Important Notes

Four locking keys on internal threads M 6 and over. Two locking keys on internal threads smaller than M 6.
 Installation (Inst.) drill size, counter sink, thread tap and thread depth as specified in table.
 Removal (Rem.) drill size and drill depth as specified in table.
 Perform to standards: NA0148

Order No.	Type	d ₁ tol. 4H 5H	Thread type d ₁	d ₂ tol. 4h	Thread type d ₂	Inst. tap drill size	l ₁
TR1609.81351	SL	M 5x0,8	Coarse	M 8x1,25	Coarse	6.90	8.0
TR1609.81551	SL	M 5x0,5	Fine	M 8x1,25	Coarse	6.90	8.0
TR1609.81352	SL	M 6x1,0	Coarse	M10x1,25	Fine	8.80	10.0
TR1609.81552	SL	M 6x0,75	Fine	M10x1,25	Fine	8.80	10.0
TR1609.81353	SL	M 8x1,25	Coarse	M12x1,25	Fine	10.80	12.0
TR1609.81553	SL	M 8x1,0	Fine	M12x1,25	Fine	10.80	12.0
TR1609.81355	SL	M10x1,5	Coarse	M14x1,5	Fine	12.80	14.0
TR1609.81555	SL	M10x1,25	Fine	M14x1,5	Fine	12.80	14.0
TR1609.81356	SL	M12x1,75	Coarse	M16x1,5	Fine	14.75	16.0
TR1609.81556	SL	M12x1,25	Fine	M16x1,5	Fine	14.75	16.0

Order No.	l ₃ ±0.76	l ₄ c'bore depth	C'sink hole size +0.25 -0.00	Inst. thread tap tol. 6H	Inst. thread tap depth min.	Inst. tool ref. T11712	Removal drill depth	Removal drill size
TR1609.81351	3.73	1.27	8.25	M 8x1,25	9.5	.0510	4.00	5.50
TR1609.81551	3.73	1.27	8.25	M 8x1,25	9.5	.0510	4.00	5.50
TR1609.81352	6.02	1.78	10.25	M10x1,25	11.5	.0520	4.75	7.50
TR1609.81552	6.02	1.78	10.25	M10x1,25	11.5	.0520	4.75	7.50
TR1609.81353	6.28	1.78	12.25	M12x1,25	13.5	.0530	4.75	9.50
TR1609.81553	6.28	1.78	12.25	M12x1,25	13.5	.0530	4.75	9.50
TR1609.81355	6.46	2.29	14.25	M14x1,5	15.5	.0550	4.75	11.50
TR1609.81555	6.46	2.29	14.25	M14x1,5	15.5	.0550	4.75	11.50
TR1609.81356	6.46	2.29	16.25	M16x1,5	17.5	.0560	4.75	13.50
TR1609.81556	6.46	2.29	16.25	M16x1,5	17.5	.0560	4.75	13.50



Threaded Insert MS/NAS - Thinwall - 4140 steel - non-locking - MS/NAS grade

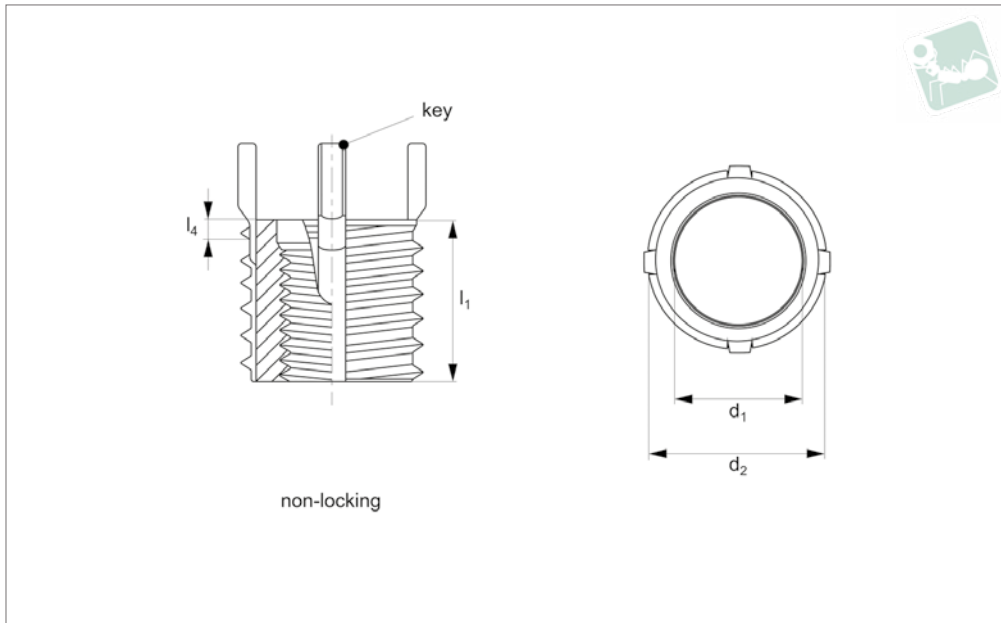
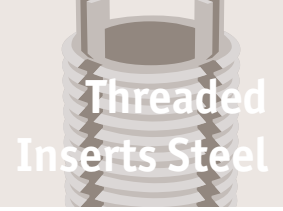

TR1662

THREADED INSERTS STEEL

Material

Inserts - 4140 alloy steel (160 KSI Min).
Keys - 302 CRES.
Cadmium plate (QQ-P-416 Type II, Cl. 2).
Dry film lubrication on self-locking inserts only.

Technical Notes

All dimensions in inches.
Internal threads: to SAE AS8879.
General tolerances -

+/- 0,010 unless specified.

Tap drill hole tolerances -
0,234 to 0,500 = +0,004/-0,001
0,500 and over = +0,005/-0,001
NL = Non-Locking type.

Tips

Order installation tool separately, as identified by „Inst. Tool ref.“ in table.

Important Notes

Four locking keys on internal threads 5/16 and over. Two locking keys on internal threads smaller than 5/16.
Installation (Inst.) drill size, counter sink, thread tap and thread depth as specified in table.
Removal (Rem.) drill size and drill depth as specified in table.
Perform to standards: MIL-I-45914A

Order No.	Type	d ₁ class 3B	Thread type d ₁	d ₂ (mod.) class 2A	Thread type d ₂	Inst. tap drill size	l ₁	l ₄ c'bore depth	Inst. c'sink hole size +0.010 - 0.000	Inst. thread depth min.	Inst. tap size class 2B	Inst. tool ref. TR1702	Removal drill depth	Removal drill size
TR1662.80321	NL	10-24	UNC	5/16-18	UNC	,272	,312	,07	,323	,37	5/16-18	.0210	5/32	7/32
TR1662.80521	NL	10-32	UNF	5/16-18	UNC	,272	,312	,07	,323	,37	5/16-18	.0211	5/32	7/32
TR1662.80322	NL	1/4-20	UNC	3/8-16	UNC	,332	,375	,07	,385	,43	3/8-16	.0220	3/16	9/32
TR1662.80522	NL	1/4-28	UNF	3/8-16	UNC	,332	,375	,07	,385	,43	3/8-16	.0221	3/16	9/32
TR1662.80323	NL	5/16-18	UNC	7/16-14	UNC	,397	,437	,07	,447	,50	7/16-14	.0230	3/16	11/32
TR1662.80523	NL	5/16-24	UNF	7/16-14	UNC	,397	,437	,07	,447	,50	7/16-14	.0231	3/16	11/32
TR1662.80324	NL	3/8-16	UNC	1/2-13	UNC	,453	,500	,07	,510	,56	1/2-13	.0240	3/16	13/32
TR1662.80524	NL	3/8-24	UNF	1/2-13	UNC	,453	,500	,07	,510	,56	1/2-13	.0241	3/16	13/32
TR1662.80325	NL	7/16-14	UNC	9/16-12	UNC	,516	,562	,07	,572	,62	9/16-12	.0250	3/16	15/32
TR1662.80525	NL	7/16-20	UNF	9/16-12	UNC	,516	,562	,07	,572	,62	9/16-12	.0251	3/16	15/32
TR1662.80326	NL	1/2-13	UNC	5/8-11	UNC	,578	,625	,07	,635	,68	5/8-11	.0260	3/16	17/32
TR1662.80526	NL	1/2-20	UNF	5/8-11	UNC	,578	,625	,07	,635	,68	5/8-11	.0261	3/16	17/32



TR1663

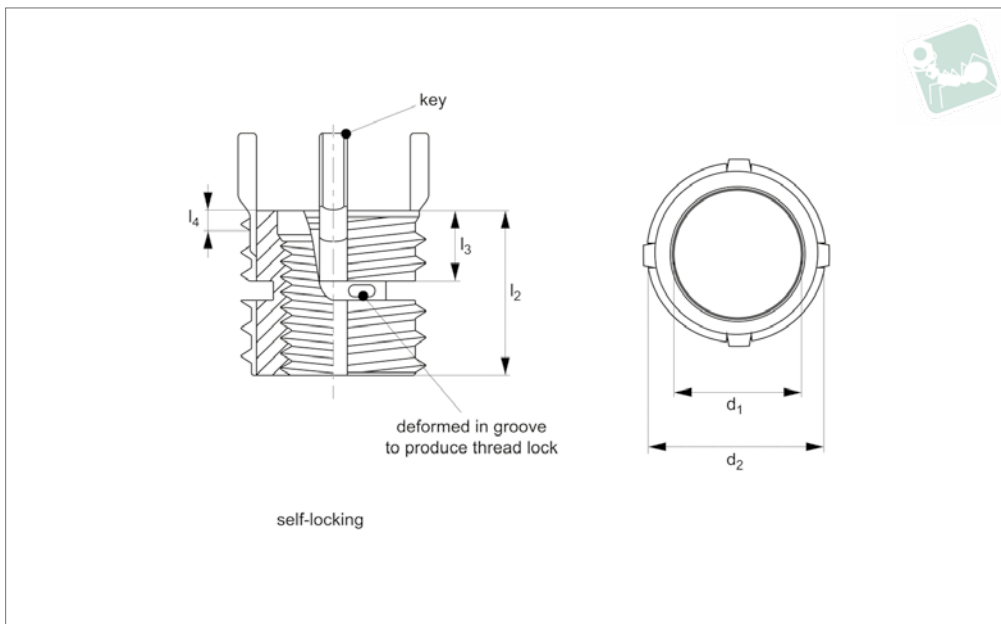

Material

Inserts - 4140 alloy steel (160 KSI Min).
 Keys - 302 CRES.
 Cadmium plate (QQ-P-416 Type II, Cl. 2).
 Dry film lubrication on self-locking inserts only.

Technical Notes

All dimensions in inches.
 Internal threads: to SAE AS8879.
 General tolerances -
 +/- 0,010 unless specified.

Tap drill hole tolerances -

0,234 to 0,500 = +0,004/-0,001
 0,500 and over = +0,005/-0,001
SL = Self-Locking type, deliberate deformity in thread produces self-affect once installed (see technical diagram).

Tips

Order installation tool separately, as identified by „Inst. Tool ref.“ in table.

Important Notes

Four locking keys on internal threads 5/16 and over. Two locking keys on internal threads smaller than 5/16.
 Installation (Inst.) drill size, counter sink, thread tap and thread depth as specified in table.
 Removal (Rem.) drill size and drill depth as specified in table.
 Perform to standards: MIL-I-45914A (MS51830 & NAS1394)

Order No.	Type	d ₁ class 3B	Thread type d ₁	d ₂ (mod.) class 2A	Thread type d ₂	Inst. tap drill size	l ₁	l ₃ ±0.03 0	l ₄ c'bore depth	Inst. c'sink hole size +0.010 - 0.000	Inst. thread depth min.	Inst. thread tap size class 2B	Inst. tool ref. TR1702	Removal drill depth	Removal drill size
TR1663.81321	SL	10-24	UNC	5/16-18	UNC	,272	,312	,22	,07	,323	,37	5/16-18	.0210	5/32	7/32
TR1663.81521	SL	10-32	UNF	5/16-18	UNC	,272	,312	,22	,07	,323	,37	5/16-18	.0211	5/32	7/32
TR1663.81322	SL	1/4-20	UNC	3/8-16	UNC	,332	,375	,22	,07	,385	,43	3/8-16	.0220	3/16	9/32
TR1663.81522	SL	1/4-28	UNF	3/8-16	UNC	,332	,375	,22	,07	,385	,43	3/8-16	.0221	3/16	9/32
TR1663.81323	SL	5/16-18	UNC	7/16-14	UNC	,397	,437	,22	,07	,447	,50	7/16-14	.0230	3/16	11/32
TR1663.81523	SL	5/16-24	UNF	7/16-14	UNC	,397	,437	,22	,07	,447	,50	7/16-14	.0231	3/16	11/32
TR1663.81324	SL	3/8-16	UNC	1/2-13	UNC	,453	,500	,24	,07	,510	,56	1/2-13	.0240	3/16	13/32
TR1663.81524	SL	3/8-24	UNF	1/2-13	UNC	,453	,500	,24	,07	,510	,56	1/2-13	.0241	3/16	13/32
TR1663.81325	SL	7/16-14	UNC	9/16-12	UNC	,516	,562	,27	,07	,572	,62	9/16-12	.0250	3/16	15/32
TR1663.81525	SL	7/16-20	UNF	9/16-12	UNC	,516	,562	,27	,07	,572	,62	9/16-12	.0251	3/16	15/32
TR1663.81326	SL	1/2-13	UNC	5/8-11	UNC	,578	,625	,28	,07	,635	,68	5/8-11	.0260	3/16	17/32
TR1663.81526	SL	1/2-20	UNF	5/8-11	UNC	,578	,625	,28	,07	,635	,68	5/8-11	.0261	3/16	17/32



Threaded Insert - Metric

heavy duty - carbon steel

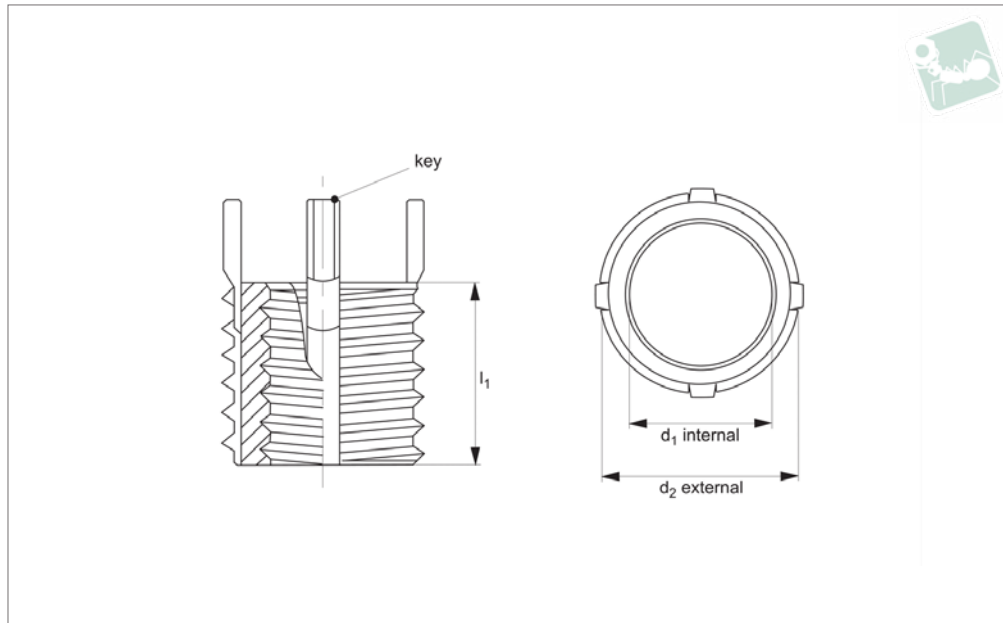
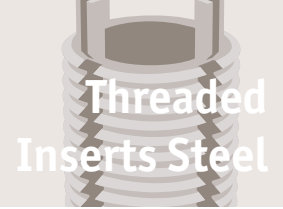

TR1525

THREADED INSERTS STEEL

Material

Inserts: carbon steel (C1215) or equivalent. Zinc phosphate.

Keys: stainless steel (302 CRES) or equivalent. Passivated.

Technical Notes

General tolerances:

±0,25, unless specified.

Tap drill hole tolerances:

6,9 to 10,8 = +0,10/-0,025.

12,8 and over = +0,13/-0,025.

Tips

Order installation tool separately, as identified by „Inst. tool ref.“ in table.

Important Notes

Four locking keys on internal threads M 8 and over. Two locking keys on internal threads smaller than M 8.

Installation (Inst.) drill size, countersink, thread tap and thread depth as specified in table.

Removal drill size and drill depth as speci-

Order No.	Int. d ₁ tol. 6H	Int. thread type d ₁	Ext. d ₂ tol. 6g	Ext. thread type d ₂	l ₁	Inst. tool ref. 22062	Inst. tap drill size	Inst. c'sink dia. ±0,25 ± 0,000	Inst. thread tap tol. 6H	Inst. thread depth min.	Removal drill size	Removal drill depth
TR1525.65963	M 4x0,70	Coarse	M 8x1,25	Coarse	8	.W0630	6,9	8,3	M 8x1,25	9,5	5,5	4,0
TR1525.65964	M 5x0,80	Coarse	M10x1,25	Fine	10	.W0640	8,8	10,3	M10x1,25	12,5	7,5	4,8
TR1525.65965	M 6x1,00	Coarse	M12x1,25	Fine	12	.W0650	10,8	12,3	M12x1,25	14,5	9,5	4,8
TR1525.65966	M 8x1,25	Coarse	M14x1,50	Fine	14	.W0660	12,8	14,3	M14x1,50	16,5	11,5	4,8
TR1525.66166	M 8x1,00	Fine	M14x1,50	Fine	14	.W0660	12,8	14,3	M14x1,50	16,5	11,5	4,8
TR1525.65967	M10x1,50	Coarse	M16x1,50	Fine	16	.W0670	14,8	16,3	M16x1,50	18,5	13,5	4,8
TR1525.66167	M10x1,25	Fine	M16x1,50	Fine	16	.W0670	14,8	16,3	M16x1,50	18,5	13,5	4,8
TR1525.65969	M12x1,75	Coarse	M18x1,50	Fine	18	.W0690	16,8	18,3	M18x1,50	20,5	15,5	4,8
TR1525.66169	M12x1,25	Fine	M18x1,50	Fine	18	.W0690	16,8	18,3	M18x1,50	20,5	15,5	4,8
TR1525.65970	M14x2,00	Coarse	M20x1,50	Fine	20	.W0700	18,8	20,3	M20x1,50	22,5	17,5	4,8
TR1525.66170	M14x1,50	Fine	M20x1,50	Fine	20	.W0700	18,8	20,3	M20x1,50	22,5	17,5	4,8
TR1525.65971	M16x2,00	Coarse	M22x1,50	Fine	22	.W0710	20,5	22,3	M22x1,50	24,5	17,8	6,4
TR1525.66171	M16x1,50	Fine	M22x1,50	Fine	22	.W0710	20,5	22,3	M22x1,50	24,5	17,8	6,4
TR1525.66172	M18x1,50	Fine	M24x1,50	Fine	24	.W0720	22,5	24,3	M24x1,50	26,5	19,8	6,4
TR1525.65973	M20x2,50	Coarse	M30x2,00	Non-Std	30	.W0730	28,0	30,3	M30x2,00	34,5	25,8	6,4
TR1525.66173	M20x1,50	Fine	M30x2,00	Non-Std	30	.W0730	28,0	30,3	M30x2,00	34,5	25,8	6,4
TR1525.66174	M22x1,50	Fine	M32x2,00	Non-Std	32	.W0740	30,0	32,3	M32x2,00	36,5	27,8	6,4
TR1525.65975	M24x3,00	Coarse	M33x2,00	Non-Std	33	.W0750	31,0	33,3	M33x2,00	37,5	28,8	6,4
TR1525.66175	M24x2,00	Fine	M33x2,00	Non-Std	33	.W0750	31,0	33,3	M33x2,00	37,5	28,8	6,4



TR1535

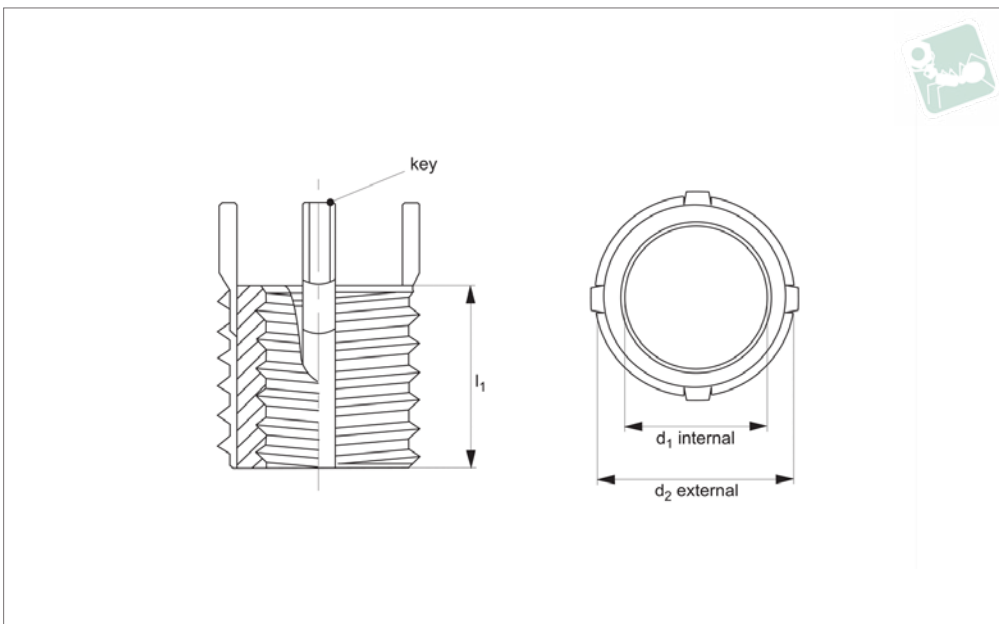

Material

Inserts: carbon steel (C1215) or equivalent. Zinc phosphate.

Keys: stainless steel (302 CRES) or equivalent. Passivated.

Technical Notes

General tolerances:

± 0,010" unless specified.

Tap drill hole tolerances:

0,234 to 0,500 = +0,004/-0,001"
0,500 and over = +0,005/-0,001"

Tips

Order installation tool separately, as identified by „Inst. tool ref.“ in table.

Important Notes

Four locking keys on internal threads M8 and over. Two locking keys on internal

threads smaller than M8.

Installation (Inst.) drill size, countersink, thread tap and thread depth as specified in table.

Removal drill size and drill depth as specified in table.

Internal thread in metric. External thread in inches.

Order No.	Int. d ₁ tol. 6H	Int. thread type d ₁	Ext. d ₂ tol. 2A	Ext. thread type d ₂	l ₁	Inst. tool ref. 22064	Inst. tap drill size	Inst. c'sink dia. +0.010 - 0.000	Inst. thread tap tol. 2B	Inst. thread depth min.	Removal drill size	Removal drill depth
TR1535.66243	M 6x1,00	Coarse	3/8"-16	UNC	0,31	.W0430	21/64"	0,38	3/8"-16	0,37	9/32"	1/8"
TR1535.66244	M 8x1,25	Coarse	1/2"-13	UNC	0,43	.W0440	29/64"	0,51	1/2"-13	0,50	13/32"	3/16"
TR1535.66245	M10x1,50	Coarse	5/8"-11	UNC	0,50	.W0450	37/64"	0,63	5/8"-11	0,56	17/32"	3/16"
TR1535.66247	M12x1,75	Coarse	3/4"-16	UNF	0,62	.W0470	45/64"	0,76	3/4"-16	0,68	21/32"	3/16"
TR1535.66248	M14x2,00	Coarse	7/8"-14	UNF	0,81	.W0480	53/64"	0,88	7/8"-14	0,94	25/32"	5/16"
TR1535.66249	M16x2,00	Coarse	1"-12	UNF	0,87	.W0490	15/16"	1,02	1"-12	1,00	27/32"	5/16"



Threaded Insert - Inch heavy duty - carbon steel



TR1575

THREADED INSERTS STEEL

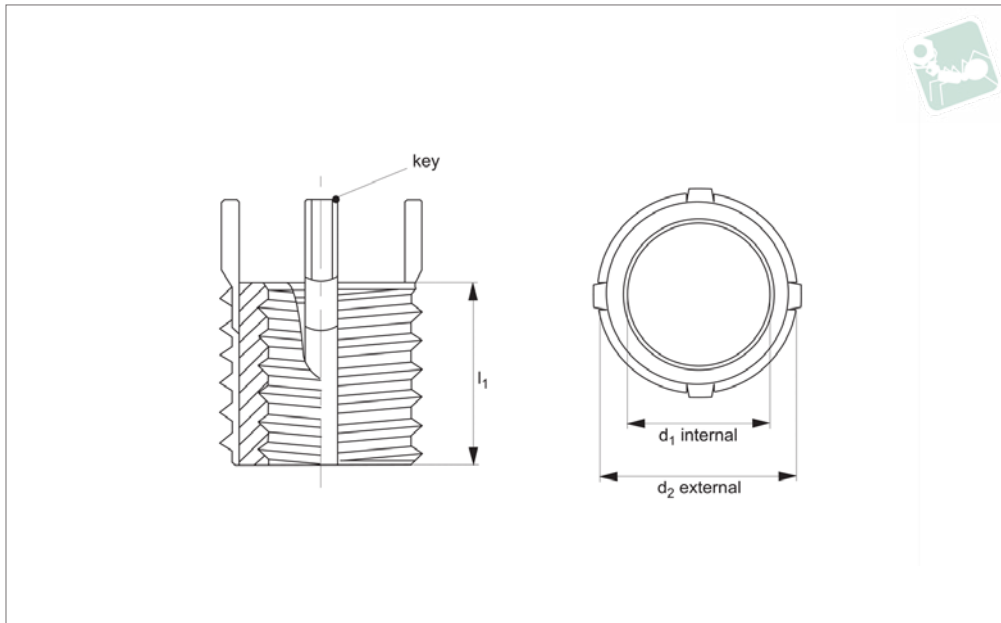

Material

Inserts: carbon steel (C1215) or equivalent. Zinc phosphate.

Keys: stainless steel (302 CRES) or equivalent. Passivated.

Technical Notes

General tolerances:

± 0,010" unless specified.

Tap drill hole tolerances:

0,234 to 0,500 = +0,004/-0,001".

0,500 and over = +0,005/-0,001".

Tips

Order installation tool separately, as identified by „Inst. tool ref.“ in table.

Important Notes

Four locking keys on internal threads 5/16" and over. Two locking keys on internal

threads smaller than 5/16".

Installation (Inst.) drill size, countersink, thread tap and thread depth as specified in table.

Removal drill size and drill depth as specified in table.

All dimensions in inches.

Order No.	Int. d ₁ tol. 2B	Int. thread type d ₁	Ext. d ₂ tol. 2A	Ext. thread type d ₂	l ₁	Inst. tool ref. 22056	Inst. tap drill size	Inst. c'sink dia. +0.010 - 0.000	Inst. thread tap tol. 2B	Inst. thread depth min.	Removal drill size	Removal drill depth
TR1575.65900	8-32	UNC	5/16"-18	UNC	0,31	.W0000	17/64"	0,32	5/16"-18	0,37	7/32"	1/8"
TR1575.65901	10-24	UNC	3/8"-16	UNC	0,31	.W0010	21/64"	0,38	3/8"-16	0,37	9/32"	1/8"
TR1575.66101	10-32	UNF	3/8"-16	UNC	0,31	.W0010	21/64"	0,38	3/8"-16	0,37	9/32"	1/8"
TR1575.65902	1/4"-20	UNC	7/16"-14	UNC	0,37	.W0020	25/64"	0,44	7/16"-14	0,43	11/32"	3/16"
TR1575.66102	1/4"-28	UNF	7/16"-14	UNC	0,37	.W0020	25/64"	0,44	7/16"-14	0,43	11/32"	3/16"
TR1575.65903	5/16"-18	UNC	1/2"-13	UNC	0,43	.W0030	29/64"	0,51	1/2"-13	0,50	13/32"	3/16"
TR1575.66103	5/16"-24	UNF	1/2"-13	UNC	0,43	.W0030	29/64"	0,51	1/2"-13	0,50	13/32"	3/16"
TR1575.65904	3/8"-16	UNC	9/16"-12	UNC	0,50	.W0040	33/64"	0,57	9/16"-12	0,56	15/32"	3/16"
TR1575.66104	3/8"-24	UNF	9/16"-12	UNC	0,50	.W0040	33/64"	0,57	9/16"-12	0,56	15/32"	3/16"
TR1575.65905	7/16"-14	UNC	5/8"-11	UNC	0,62	.W0050	37/64"	0,63	5/8"-11	0,68	17/32"	3/16"
TR1575.66105	7/16"-20	UNF	5/8"-11	UNC	0,62	.W0050	37/64"	0,63	5/8"-11	0,68	17/32"	3/16"
TR1575.65906	1/2"-13	UNC	3/4"-16	UNF	0,62	.W0060	45/64"	0,76	3/4"-16	0,68	21/32"	3/16"
TR1575.66106	1/2"-20	UNF	3/4"-16	UNF	0,62	.W0060	45/64"	0,76	3/4"-16	0,68	21/32"	3/16"
TR1575.65907	9/16"-12	UNC	3/4"-16	UNF	0,81	.W0070	45-64"	0,76	3/4"-16	0,94	21/32"	3/16"
TR1575.66107	9/16"-18	UNF	3/4"-16	UNF	0,81	.W0070	45-64"	0,76	3/4"-16	0,94	21/32"	3/16"
TR1575.65908	5/8"-11	UNC	7/8"-14	UNF	0,87	.W0080	53/64"	0,88	7/8"-14	1,00	25/32"	5/16"
TR1575.66108	5/8"-18	UNF	7/8"-14	UNF	0,87	.W0080	53/64"	0,88	7/8"-14	1,00	25/32"	5/16"
TR1575.65909	3/4"-10	UNC	1-1/8"-12	UNF	1,12	.W0090	1-1/16"	1,14	1-1/8"-12	1,31	31/32"	5/16"
TR1575.66109	3/4"-16	UNF	1-1/8"-12	UNF	1,12	.W0090	1-1/16"	1,14	1-1/8"-12	1,31	31/32"	5/16"
TR1575.65910	7/8"-9	UNC	1-1/4"-12	UNF	1,25	.W0100	1-3/16"	1,27	1-1/4"-12	1,44	1-3/32"	5/16"
TR1575.66110	7/8"-14	UNF	1-1/4"-12	UNF	1,25	.W0100	1-3/16"	1,27	1-1/4"-12	1,44	1-3/32"	5/16"
TR1575.65911	1"-8	UNC	1-3/8"-12	UNF	1,37	.W0110	1-5/16"	1,39	1-3/8"-12	1,56	1-7/32"	5/16"
TR1575.66111	1"-12	UNF	1-3/8"-12	UNF	1,37	.W0110	1-5/16"	1,39	1-3/8"-12	1,56	1-7/32"	5/16"
TR1575.66112	1"-14	UNF	1-3/8"-12	UNF	1,37	.W0110	1-5/16"	1,39	1-3/8"-12	1,56	1-7/32"	5/16"
TR1575.65913	1-1/8"-7	UNC	1-1/2"-12	UNF	1,62	.W0130	1-7/16"	1,52	1-1/2"-12	1,84	1-11/32"	5/16"
TR1575.66113	1-1/8"-12	UNF	1-1/2"-12	UNF	1,62	.W0130	1-7/16"	1,52	1-1/2"-12	1,84	1-11/32"	5/16"



Order No.	Int. d ₁ tol. 2B	Int. thread type d ₁	Ext. d ₂ tol. 2A	Ext. thread type d ₂	l ₁	Inst. tool ref. 22056	Inst. tap drill size	Inst. c'sink dia. +0.010 - 0.000	Inst. thread tap tol. 2B	Inst. thread depth min.	Removal drill size	Removal drill depth
TR1575.65914	1-1/4"-7	UNC	1-5/8"-12	UNF	1,81	.W0140	1-9/16"	1,64	1-5/8"-12	2,06	1-15/32"	5/16"
TR1575.66114	1-1/4"-12	UNF	1-5/8"-12	UNF	1,81	.W0140	1-9/16"	1,64	1-5/8"-12	2,06	1-15/32"	5/16"
TR1575.65916	1-1/2"-6	UNC	1-7/8"-12	UNF	2,00	.W0160	1-13/16"	1,89	1-7/8"-12	2,28	1-23/32"	5/16"
TR1575.66116	1-1/2"-12	UNF	1-7/8"-12	UNF	2,00	.W0160	1-13/16"	1,89	1-7/8"-12	2,28	1-23/32"	5/16"



Threaded Insert - Inch

extra heavy duty - carbon steel

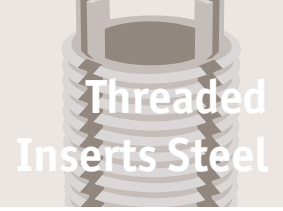

Threaded Inserts Steel

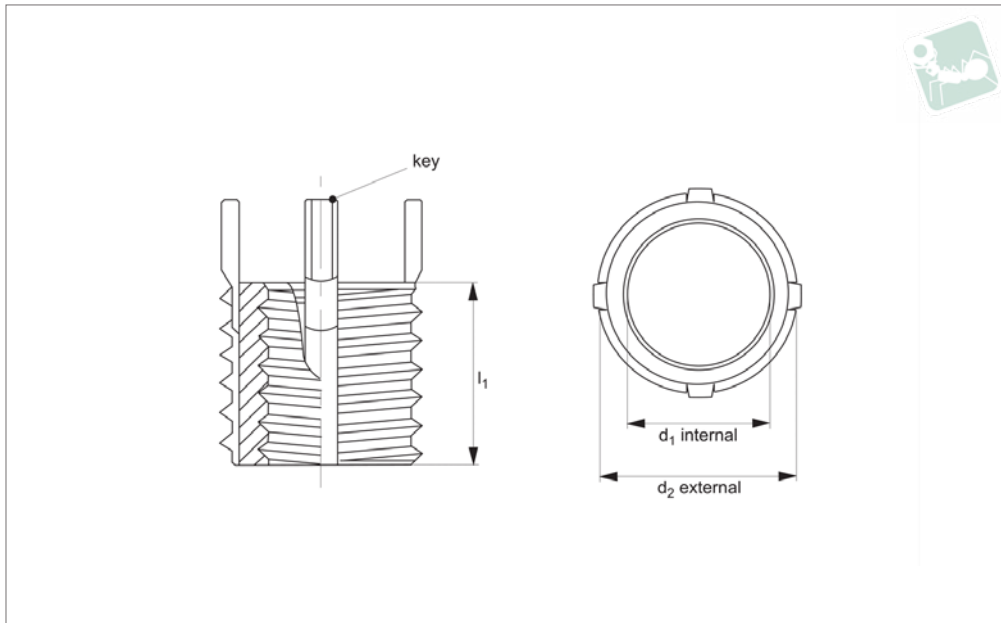

TR1576

THREADED INSERTS STEEL

Material

Inserts: carbon steel (C1215) or equivalent. Zinc phosphate.

Keys: stainless steel (302 CRES) or equivalent. Passivated.

Technical Notes

General tolerances:

± 0,010" unless specified.

Tap drill hole tolerances:

0,234 to 0,500 = +0,004/-0,001".
0,500 and over = +0,005/-0,001".

Tips

Order installation tool separately, as identified by „Inst. tool ref.“ in table.

Important Notes

Four locking keys on internal threads 5/16" and over. Two locking keys on internal

threads smaller than 5/16".

Installation (Inst.) drill size, countersink, thread tap and thread depth as specified in table.

Removal drill size and drill depth as specified in table.

All dimensions in inches.

Order No.	Int. d ₁ tol. 2B	Int. thread type d ₁	Ext. d ₂ (mod.) class 2A	Ext. thread type d ₂	l ₁	Inst. c'sink dia. +0.010 - 0.000	Inst. tap drill size	Inst. thread depth min.	Inst. thread tap tol. 2B	Inst. tool ref. 22058	Removal drill size	Removal drill depth
TR1576.65931	6 - 32	UNC	5/16" - 18	UNC	0,31	0,32		0,37	5/16"-18	.W0310	7/32"	1/8"
TR1576.65932	8 - 32	UNC	3/8" - 16	UNC	0,31	0,38		0,37	3/8"-16	.W0320	9/32"	1/8"
TR1576.65933	10 - 24	UNC	7/16" - 14	UNC	0,31	0,44		0,37	7/16"-14	.W0330	11/32"	3/16"
TR1576.66133	10 - 32	UNF	7/16" - 14	UNC	0,31	0,44		0,37	7/16"-14	.W0330	11/32"	3/16"
TR1576.65934	1/4" - 20	UNC	1/2" - 13	UNC	0,37	0,51	29/64"	0,43	1/2"-13	.W0340	13/32"	3/16"
TR1576.66134	1/4" - 28	UNF	1/2" - 13	UNC	0,37	0,51	29/64"	0,43	1/2"-13	.W0340	13/32"	3/16"
TR1576.65935	5/16" - 18	UNC	9/16" - 12	UNC	0,43	0,57	33/64"	0,50	9/16"-12	.W0350	15/32"	3/16"
TR1576.66135	5/16" - 24	UNF	9/16" - 12	UNC	0,43	0,57	33/64"	0,50	9/16"-12	.W0350	15/32"	3/16"
TR1576.65936	3/8" - 16	UNC	5/8" - 11	UNC	0,50	0,63	37/64"	0,56	5/8"-11	.W0360	17/32"	3/16"
TR1576.66136	3/8" - 24	UNF	5/8" - 11	UNC	0,50	0,63	37/64"	0,56	5/8"-11	.W0360	17/32"	3/16"
TR1576.65937	7/6" - 14	UNC	3/4" - 16	UNF	0,62	0,76	45/64"	0,68	3/4"-16	.W0370	21/32"	3/16"
TR1576.66137	7/6" - 20	UNF	3/4" - 16	UNF	0,62	0,76	45/64"	0,68	3/4"-16	.W0370	21/32"	3/16"
TR1576.65938	1/2" - 13	UNC	7/8" - 14	UNF	0,68	0,88	53/64"	0,75	7/8"-14	.W0380	25/32"	5/16"
TR1576.66138	1/2" - 13	UNF	7/8" - 14	UNF	0,68	0,88	53/64"	0,75	7/8"-14	.W0380	25/32"	5/16"
TR1576.65939	9/16" - 12	UNC	7/8" - 14	UNF	0,81	0,88	53/64"	0,94	7/8"-14	.W0390	25/32"	5/16"
TR1576.66139	9/16" - 18	UNF	7/8" - 14	UNF	0,81	0,88	53/64"	0,94	7/8"-14	.W0390	25/32"	5/16"
TR1576.65940	5/8" - 11	UNC	1" - 12	UNF	0,87	1,02	15/16"	1,00	1"-12	.W0400	27/32"	5/16"
TR1576.66140	5/8" - 18	UNF	1" - 12	UNF	0,87	1,02	15/16"	1,00	1"-12	.W0400	27/32"	5/16"
TR1576.65941	3/4" - 10	UNC	1 - 1/4" - 12	UNF	1,12	1,27	1-3/16"	1,31	1-1/4"-12	.W0410	1-3/32"	5/16"
TR1576.66141	3/4" - 16	UNF	1 - 1/4" - 12	UNF	1,12	1,27	1-3/16"	1,31	1-1/4"-12	.W0410	1-3/32"	5/16"
TR1576.65942	7/8" - 9	UNC	1 - 3/8" - 12	UNF	1,25	1,39	1-5/16"	1,44	1-3/8"-12	.W0420	1-7/32"	5/16"
TR1576.66142	7/8" - 14	UNF	1 - 3/8" - 12	UNF	1,25	1,39	1-5/16"	1,44	1-3/8"-12	.W0420	1-7/32"	5/16"
TR1576.65943	1" - 8	UNC	1 - 1/2" - 12	UNF	1,37	1,52	1-7/16"	1,56	1-1/2"-12	.W0430	1-11/32"	5/16"
TR1576.66143	1" - 12	UNF	1 - 1/2" - 12	UNF	1,37	1,52	1-7/16"	1,56	1-1/2"-12	.W0430	1-11/32"	5/16"



TR1610

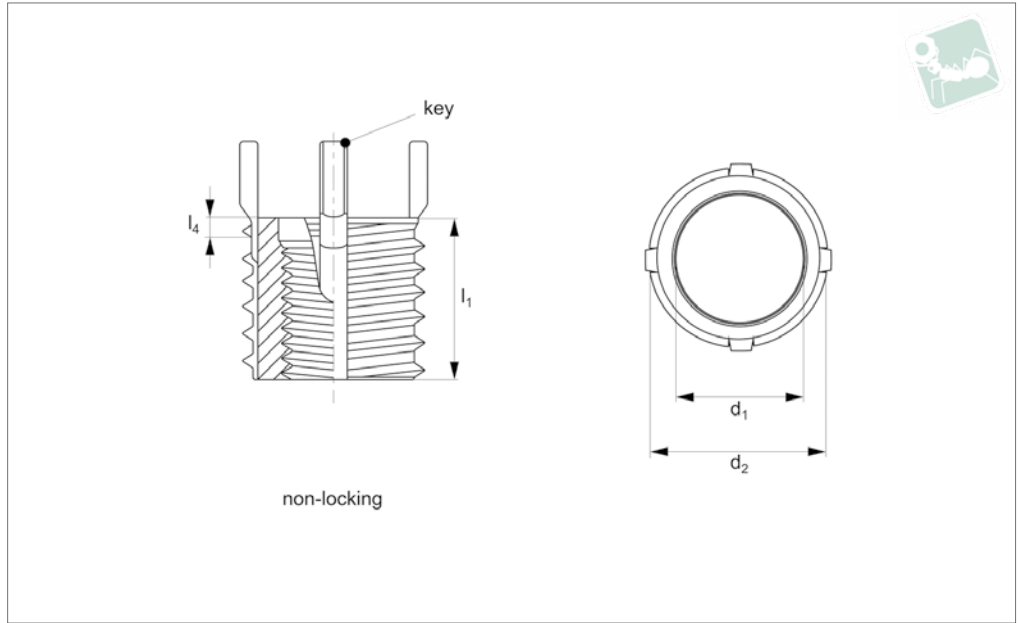

Material

Inserts - 4140 alloy steel (160 KSI Min).
 Keys - 302 CRES.
 Cadmium plate (QQ-P-416 Type II, Cl. 2).
 Dry film lubrication on self-locking inserts only.

Technical Notes

All dimensions in millimetres.
 Internal threads: to Fed. Std. H28/21, MJ Form

General tolerances -

+/- 0,25mm, unless specified.
 Tap drill hole tolerances -
 6,9 to 10,8 = +0,100/-0,025
 12,8 and over = +0,130/-0,025
NL = Non-Locking type.

Tips

Order installation tool separately, as identified by „Inst. Tool ref.“ in table.

Important Notes

Four locking keys on internal threads M 6 and over. Two locking keys on internal threads smaller than M 6.
 Installation (Inst.) drill size, counter sink, thread tap and thread depth as specified in table.
 Removal (Rem.) drill size and drill depth as specified in table.
 Perform to standards: NA0150

Order No.	Type	d ₁ tol. 4H 5H	Thread type d ₁	d ₂ tol. 4h	Thread type d ₂	l ₁	l ₄ c'bore depth	C'sink hole size +0.25 - 0.00	Inst. tap drill size	Inst. thread tap tol. 6H	Inst. thread tap depth min.	Inst. tool ref. TR1715	Removal drill size	Removal drill size
TR1610.80363	NL	M 4x0,7	Coarse	M 8x1,25	Coarse	8,0	1,27	8,25	6,90	M 8x1,25	9,5	.0630	5,50	5,50
TR1610.80364	NL	M 5x0,8	Coarse	M10x1,25	Fine	10,0	1,27	10,25	8,80	M10x1,25	12,5	.0640	7,50	7,50
TR1610.80365	NL	M 6x1,0	Coarse	M12x1,25	Fine	12,0	1,78	12,25	10,80	M12x1,25	14,5	.0650	9,50	9,50
TR1610.80366	NL	M 8x1,25	Coarse	M14x1,5	Fine	14,0	1,78	14,25	12,80	M14x1,5	16,5	.0660	11,50	11,50
TR1610.80566	NL	M 8x1,0	Fine	M14x1,5	Fine	14,0	1,78	14,25	12,80	M14x1,5	16,5	.0660	11,50	11,50
TR1610.80367	NL	M10x1,5	Coarse	M16x1,5	Fine	16,0	2,29	16,25	14,75	M16x1,5	18,5	.0670	13,50	13,50
TR1610.80567	NL	M10x1,25	Fine	M16x1,5	Fine	16,0	2,29	16,25	14,75	M16x1,5	18,5	.0670	13,50	13,50
TR1610.80369	NL	M12x1,75	Coarse	M18x1,5	Coarse	18,0	2,29	18,25	16,75	M18x1,5	20,5	.0690	15,50	15,50
TR1610.80569	NL	M12x1,25	Fine	M18x1,5	Coarse	18,0	2,29	18,25	16,75	M18x1,5	20,5	.0690	15,50	15,50
TR1610.80370	NL	M14x2,0	Coarse	M20x1,5	Fine	20,0	2,79	20,25	18,75	M20x1,5	22,5	.0700	17,50	17,50
TR1610.80570	NL	M14x1,5	Fine	M20x1,5	Fine	20,0	2,79	20,25	18,75	M20x1,5	22,5	.0700	17,50	17,50
TR1610.80371	NL	M16x2,0	Coarse	M22x1,5	Fine	22,0	2,79	22,25	20,50	M22x1,5	24,5	.0710	17,75	17,75
TR1610.80571	NL	M16x1,5	Fine	M22x1,5	Fine	22,0	2,79	22,25	20,50	M22x1,5	24,5	.0710	17,75	17,75
TR1610.80572	NL	M18x1,5	Coarse	M24x2,0	Fine	24,0	2,79	24,25	22,50	M 24x2,0	28,5	.0720	19,75	19,75
TR1610.80373	NL	M20x2,5	Coarse	M30x2,0	Fine	30,0	2,79	30,25	28,00	M30x2,0	34,5	.0730	25,75	25,75
TR1610.80573	NL	M20x1,5	Fine	M30x2,0	Fine	30,0	2,79	30,25	28,00	M30x2,0	34,5	.0730	25,75	25,75
TR1610.80574	NL	M22x1,5	Fine	M32x2,0	Non-Std	32,0	2,79	32,25	30,00	M32x2,0	36,5	.0740	27,75	27,75
TR1610.80375	NL	M24x3,0	Coarse	M33x2,0	Non-Std	33,0	3,81	33,25	31,00	M33x2,0	37,5	.0750	28,75	28,75
TR1610.80575	NL	M24x2,0	Fine	M33x2,0	Non-Std	33,0	3,81	33,25	31,00	M33x2,0	37,5	.0750	28,75	28,75



Threaded Insert MS/NAS - H Duty - 4140 steel - self-locking - MS/NAS grade

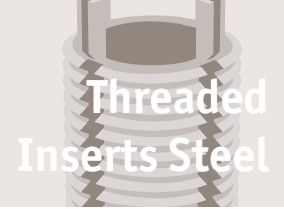

TR1611

THREADED INSERTS STEEL

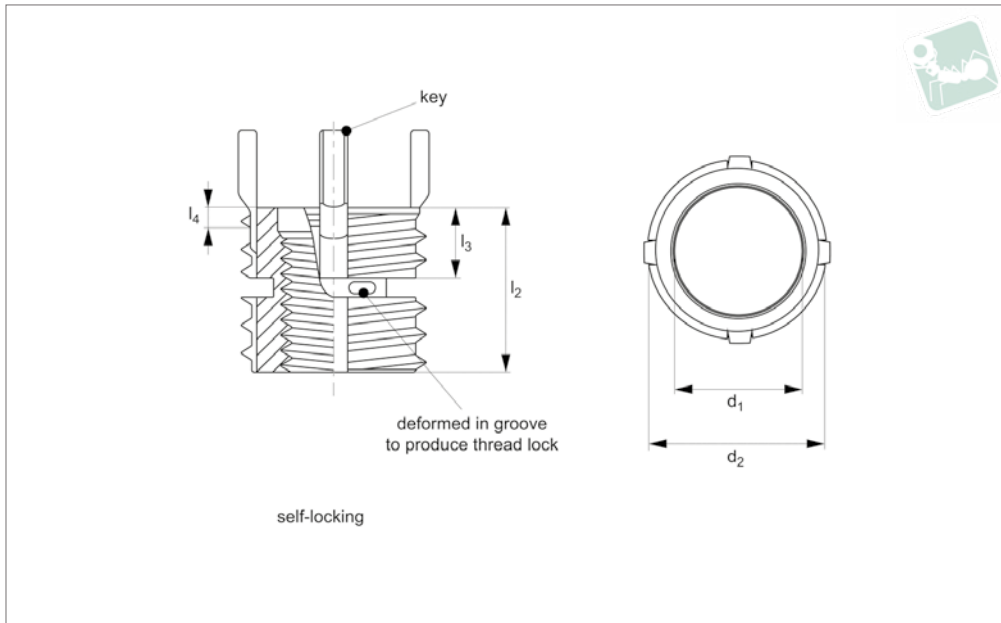

Material

Inserts - 4140 alloy steel (160 KSI Min).
Keys - 302 CRES.
Cadmium plate (QQ-P-416 Type II, Cl. 2).
Dry film lubrication on self-locking inserts only.

Technical Notes

All dimensions in millimetres.
Internal threads: to Fed. Std. H28/21, MJ Form
General tolerances -

+/- 0,25mm, unless specified.

Tap drill hole tolerances -
6,9 to 10,8 = +0,100/-0,025
12,8 and over = +0,130/-0,025

SL = Self-Locking type, deliberate deformity in thread produces self-affect once installed (see technical diagram).

Tips

Order installation tool separately, as identified by „Inst. Tool ref.“ in table.

Important Notes

Four locking keys on internal threads M 6 and over. Two locking keys on internal threads smaller than M 6.
Installation (Inst.) drill size, counter sink, thread tap and thread depth as specified in table.
Removal (Rem.) drill size and drill depth as specified in table.
Perform to standards: NA0150

Order No.	Type	d ₁ tol. 4H 5H	Thread type d ₁	d ₂ tol. 4h	Thread type d ₂	l ₁	l ₃ ±0,76	l ₄ c'bore depth	C'sink hole size +0,25 - 0,00	Inst. tap drill size	Inst. thread tap tol. 6H	Inst. thread tap depth min.	Inst. tool ref. TR1715	Removal drill size	Removal drill depth
TR1611.81363	SL	M 4x0,7	Coarse	M 8x1,25	Coarse	8,0	5,00	1,27	8,25	6,90	M 8x1,25	9,5	.0630	5,50	4,00
TR1611.81364	SL	M 5x0,8	Coarse	M10x1,25	Fine	10,0	5,50	1,27	10,25	8,80	M10x1,25	12,5	.0640	7,50	4,75
TR1611.81365	SL	M 6x1,0	Coarse	M12x1,25	Fine	12,0	6,46	1,78	12,25	10,80	M12x1,25	14,5	.0650	9,50	4,75
TR1611.81366	SL	M 8x1,25	Coarse	M14x1,5	Fine	14,0	6,46	1,78	14,25	12,80	M14x1,5	16,5	.0660	11,50	4,75
TR1611.81566	SL	M 8x1,0	Fine	M14x1,5	Fine	14,0	6,46	1,78	14,25	12,80	M14x1,5	16,5	.0660	11,50	4,75
TR1611.81367	SL	M10x1,5	Coarse	M16x1,5	Fine	16,0	6,46	2,29	16,25	14,75	M16x1,5	18,5	.0670	13,50	4,75
TR1611.81567	SL	M10x1,25	Fine	M16x1,5	Fine	16,0	6,46	2,29	16,25	14,75	M16x1,5	18,5	.0670	13,50	4,75
TR1611.81369	SL	M12x1,75	Coarse	M18x1,5	Coarse	18,0	7,23	2,29	18,25	16,75	M18x1,5	20,5	.0690	15,50	4,75
TR1611.81569	SL	M12x1,25	Fine	M18x1,5	Coarse	18,0	7,23	2,29	18,25	16,75	M18x1,5	20,5	.0690	15,50	4,75
TR1611.81370	SL	M14x2,0	Coarse	M20x1,5	Fine	20,0	7,23	2,79	20,25	18,75	M20x1,5	22,5	.0700	17,50	4,75
TR1611.81570	SL	M14x1,5	Fine	M20x1,5	Fine	20,0	7,23	2,79	20,25	18,75	M20x1,5	22,5	.0700	17,50	4,75
TR1611.81371	SL	M16x2,0	Coarse	M22x1,5	Fine	22,0	8,50	2,79	22,25	20,50	M22x1,5	24,5	.0710	17,75	6,35
TR1611.81571	SL	M16x1,5	Fine	M22x1,5	Fine	22,0	8,50	2,79	22,25	20,50	M22x1,5	24,5	.0710	17,75	6,35
TR1611.81572	SL	M18x1,5	Coarse	M24x2,0	Fine	24,0	9,25	2,79	24,25	22,50	M24x2,0	28,5	.0720	19,75	6,35
TR1611.81373	SL	M20x2,5	Coarse	M30x2,0	Fine	30,0	12,51	2,79	30,25	28,00	M30x2,0	34,5	.0730	25,75	6,35
TR1611.81573	SL	M20x1,5	Fine	M30x2,0	Fine	30,0	12,51	2,79	30,25	28,00	M30x2,0	34,5	.0730	25,75	6,35
TR1611.81574	SL	M22x1,5	Fine	M32x2,0	Non-Std	32,0	12,51	2,79	32,25	30,00	M32x2,0	36,5	.0740	27,75	6,35
TR1611.81375	SL	M24x3,0	Coarse	M33x2,0	Non-Std	33,0	13,97	3,81	33,25	31,00	M33x2,0	37,5	.0750	28,75	6,35
TR1611.81575	SL	M24x2,0	Fine	M33x2,0	Non-Std	33,0	13,97	3,81	33,25	31,00	M33x2,0	37,5	.0750	28,75	6,35



Order No.	1/4 c'bore depth	C'sink hole size	Inst. tap drill size	Inst. thread tap	Inst. thread tap depth	Inst. tool ref. TR1715	Removal drill size	Removal drill depth
TR1611.81363	1.27	8.25	6.90	M 8x1,25	9.5	.0630	5.50	4.00
TR1611.81364	1.27	10.25	8.80	M10x1,25	12.5	.0640	7.50	4.75
TR1611.81365	1.78	12.25	10.80	M12x1,25	14.5	.0650	9.50	4.75
TR1611.81366	1.78	14.25	12.80	M14x1,5	16.5	.0660	11.50	4.75
TR1611.81566	1.78	14.25	12.80	M14x1,5	16.5	.0660	11.50	4.75
TR1611.81367	2.29	16.25	14.75	M16x1,5	18.5	.0670	13.50	4.75
TR1611.81567	2.29	16.25	14.75	M16x1,5	18.5	.0670	13.50	4.75
TR1611.81369	2.29	18.25	16.75	M18x1,5	20.5	.0690	15.50	4.75
TR1611.81569	2.29	18.25	16.75	M18x1,5	20.5	.0690	15.50	4.75
TR1611.81370	2.79	20.25	18.75	M20x1,5	22.5	.0700	17.50	4.75
TR1611.81570	2.79	20.25	18.75	M20x1,5	22.5	.0700	17.50	4.75
TR1611.81371	2.79	22.25	20.50	M22x1,5	24.5	.0710	17.75	6.35
TR1611.81571	2.79	22.25	20.50	M22x1,5	24.5	.0710	17.75	6.35
TR1611.81572	2.79	24.25	22.50	M24x2,0	28.5	.0720	19.75	6.35
TR1611.81373	2.79	30.25	28.00	M30x2,0	34.5	.0730	25.75	6.35
TR1611.81573	2.79	30.25	28.00	M30x2,0	34.5	.0730	25.75	6.35
TR1611.81574	2.79	32.25	30.00	M32x2,0	36.5	.0740	27.75	6.35
TR1611.81375	3.81	33.25	31.00	M33x2,0	37.5	.0750	28.75	6.35
TR1611.81575	3.81	33.25	31.00	M33x2,0	37.5	.0750	28.75	6.35



Threaded Insert MS/NAS - H Duty - 4140 steel - non-locking - MS/NAS grade

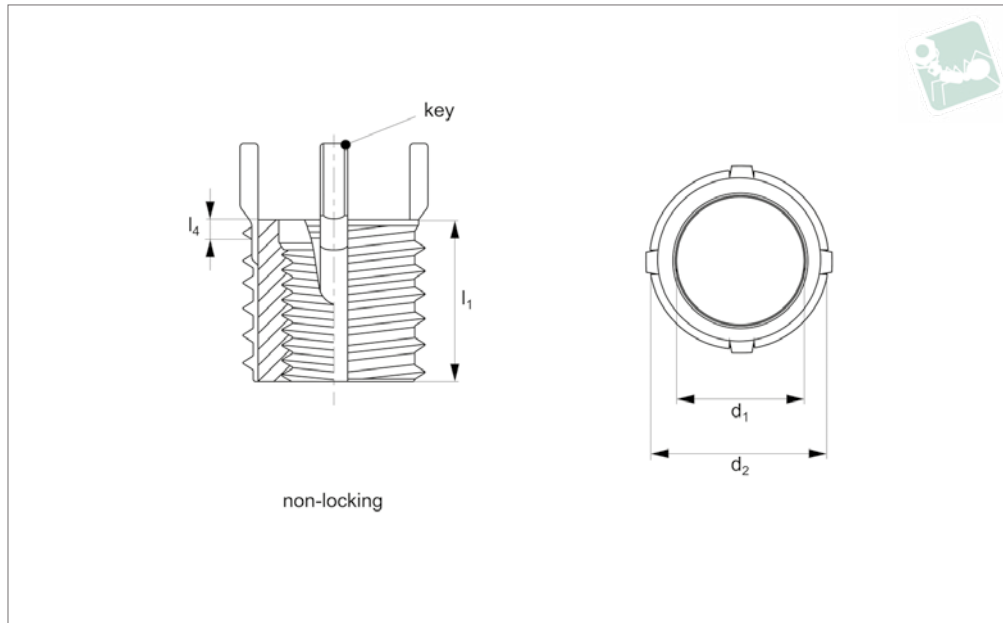

TR1664

THREADED INSERTS STEEL

Material

Inserts - 4140 alloy steel (160 KSI Min).
Keys - 302 CRES.
Cadmium plate (QQ-P-416 Type II, Cl. 2).
Dry film lubrication on self-locking inserts only.

Technical Notes

All dimensions in inches.
Internal threads: to SAE AS8879.
General tolerances -

+/- 0,010 unless specified.

Tap drill hole tolerances -
0,234 to 0,500 = +0,004/-0,001
0,500 and over = +0,005/-0,001
NL = Non-Locking type.

Tips

Order installation tool separately, as identified by „Inst. Tool ref.“ in table.

Important Notes

Four locking keys on internal threads 5/16 and over. Two locking keys on internal threads smaller than 5/16.
Installation (Inst.) drill size, counter sink, thread tap and thread depth as specified in table.
Removal (Rem.) drill size and drill depth as specified in table.
Perform to standards: MIL-I-45914A

Order No.	Type	d ₁ class 3B	Thread type d ₁	d ₂ (mod.) class 2A	Thread type d ₂	l ₁	l ₄ c'bore depth	Inst. c'sink hole size +0.010 - 0.000	Inst. tap drill size	Inst. thread tap depth min.	Inst. thread tap size class 2B	Inst. tool ref. TR1705	Removal drill size	Removal drill depth
TR1664.80300	NL	8-32	UNC	5/16-18	UNF	,312	,04	,323	,272	,37	5/16-18	.0000	7/32	1/8
TR1664.80301	NL	10-24	UNC	3/8-16	UNC	,312	,07	,385	,332	,37	3/8-16	.0010	9/32	1/8
TR1664.80501	NL	10-32	UNF	3/8-16	UNC	,312	,07	,385	,332	,37	3/8-16	.0011	9/32	1/8
TR1664.80302	NL	1/4-20	UNC	7/16-14	UNC	,375	,07	,447	,397	,43	7/16-14	.0020	11/32	3/16
TR1664.80502	NL	1/4-28	UNF	7/16-14	UNC	,375	,07	,447	,397	,43	7/16-14	.0021	11/32	3/16
TR1664.80303	NL	5/16-18	UNC	1/2-13	UNC	,437	,07	,510	,453	,50	1/2-13	.0030	13/32	3/16
TR1664.80503	NL	5/16-24	UNF	1/2-13	UNC	,437	,07	,510	,453	,50	1/2-13	.0031	13/32	3/16
TR1664.80304	NL	3/8-16	UNC	9/16-12	UNC	,500	,07	,572	,516	,56	9/16-12	.0040	15/32	3/16
TR1664.80504	NL	3/8-24	UNF	9/16-12	UNC	,500	,07	,572	,516	,56	9/16-12	.0041	15/32	3/16
TR1664.80305	NL	7/16-14	UNC	5/8-11	UNC	,625	,10	,635	,578	,68	5/8-11	.0050	17/32	3/16
TR1664.80505	NL	7/16-20	UNF	5/8-11	UNC	,625	,10	,635	,578	,68	5/8-11	.0051	17/32	3/16
TR1664.80306	NL	1/2-13	UNC	11/16-11NS	UNS	,688	,10	,700	,641	,75	11/16-11NS	.0060	19/32	3/16
TR1664.80506	NL	1/2-20	UNF	11/16-11NS	UNS	,688	,10	,700	,641	,75	11/16-11NS	.0061	19/32	3/16
TR1664.80307	NL	9/16-12	UNC	13/16-16	UN	,812	,10	,822	,766	,94	13/16-16	.0070	23/32	3/16
TR1664.80507	NL	9/16-12	UNF	13/16-16	UN	,812	,10	,885	,766	,94	13/16-16	.0071	23/32	3/16
TR1664.80308	NL	5/8-11	UNC	7/8-14	UNF	,875	,10	,885	,828	1,00	7/8-14	.0080	25/32	3/16
TR1664.80508	NL	5/8-18	UNF	7/8-14	UNF	,875	,10	,885	,828	1,00	7/8-14	.0081	25/32	3/16
TR1664.80309	NL	3/4-10	UNC	1-1/8-12	UNF	1,250	,10	1,145	1,062	1,44	1-1/8-12	.0090	31/32	5/16
TR1664.80509	NL	3/4-16	UNF	1-1/8-12	UNF	1,250	,10	1,145	1,062	1,44	1-1/8-12	.0091	31/32	5/16
TR1664.80310	NL	7/8-9	UNC	1-1/4-12	UNF	1,375	,10	1,270	1,187	1,56	1-1/4-12	.0100	1-3/32	5/16
TR1664.80510	NL	7/8-14	UNF	1-1/4-12	UNF	1,375	,10	1,270	1,187	1,56	1-1/4-12	.0101	1-3/32	5/16
TR1664.80311	NL	1-8	UNC	1-3/8-12	UNF	1,500	,10	1,395	1,312	1,68	1-3/8-12	.0110	1-7/32	5/16
TR1664.80511	NL	1-12	UNF	1-3/8-12	UNF	1,500	,10	1,395	1,312	1,68	1-3/8-12	.0111	1-7/32	5/16



TR1665

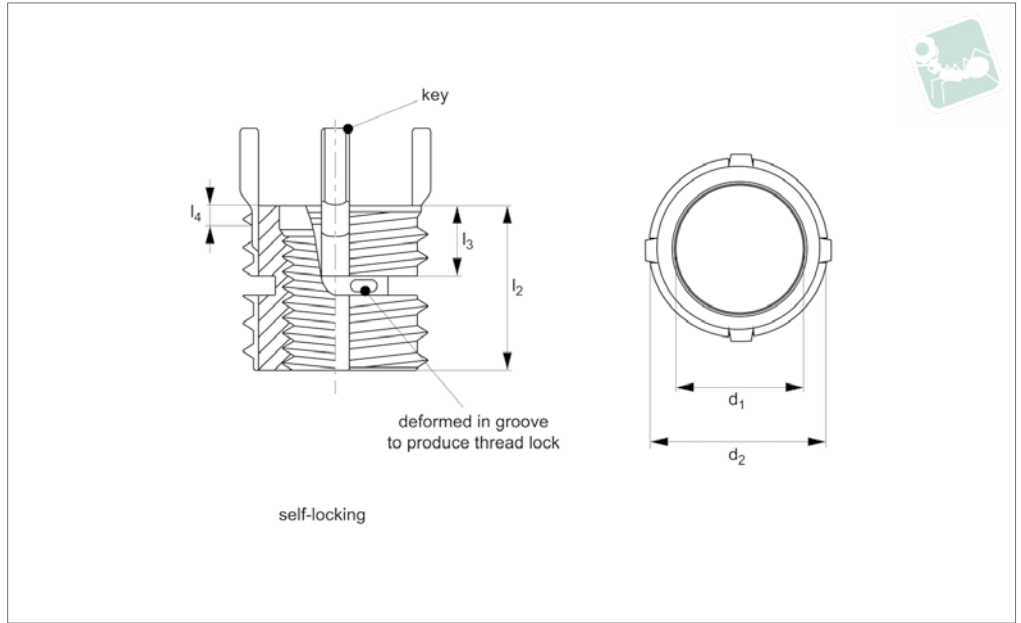

Material

Inserts - 4140 alloy steel (160 KSI Min).
 Keys - 302 CRES.
 Cadmium plate (QQ-P-416 Type II, Cl. 2).
 Dry film lubrication on self-locking inserts only.

Technical Notes

All dimensions in inches.
 Internal threads: to SAE AS8879.
 General tolerances -
 +/- 0,010 unless specified.

Tap drill hole tolerances -

0,234 to 0,500 = +0,004/-0,001
 0,500 and over = +0,005/-0,001
SL = Self-Locking type, deliberate deformity in thread produces self-affect once installed (see technical diagram).

Tips

Order installation tool separately, as identified by „Inst. Tool ref.“ in table.

Important Notes

Four locking keys on internal threads 5/16 and over. Two locking keys on internal threads smaller than 5/16.
 Installation (Inst.) drill size, counter sink, thread tap and thread depth as specified in table.
 Removal (Rem.) drill size and drill depth as specified in table.
 Perform to standards: MIL-I-45914A (MS51831 & NAS1395)

Order No.	Type	d ₁ class 3B	Thread type d ₁	d ₂ (mod.) class 2A	Thread type d ₂	l ₁	l ₃ ±0.0 30	c'bore depth	c'sink hole size +0.010 - 0.000	Inst. tap drill size	Inst. thread tap depth min.	Inst. thread tap size class 2B	Inst. tool ref. TR1705	Removal drill size	Removal drill depth
TR1665.81300	SL	8-32	UNC	5/16-18	UNF	,312	,22	,04	,323	,272	,37	5/16-18	.0000	7/32	1/8
TR1665.81301	SL	10-24	UNC	3/8-16	UNC	,312	,22	,07	,385	,332	,37	3/8-16	.0010	9/32	1/8
TR1665.81501	SL	10-32	UNF	3/8-16	UNC	,312	,22	,07	,385	,332	,37	3/8-16	.0011	9/32	1/8
TR1665.81302	SL	1/4-20	UNC	7/16-14	UNC	,375	,22	,07	,447	,397	,43	7/16-14	.0020	11/32	3/16
TR1665.81502	SL	1/4-28	UNF	7/16-14	UNC	,375	,22	,07	,447	,397	,43	7/16-14	.0021	11/32	3/16
TR1665.81303	SL	5/16-18	UNC	1/2-13	UNC	,437	,22	,07	,510	,453	,50	1/2-13	.0030	13/32	3/16
TR1665.81503	SL	5/16-24	UNF	1/2-13	UNC	,437	,22	,07	,510	,453	,50	1/2-13	.0031	13/32	3/16
TR1665.81304	SL	3/8-16	UNC	9/16-12	UNC	,500	,25	,07	,572	,516	,56	9/16-12	.0040	15/32	3/16
TR1665.81504	SL	3/8-24	UNF	9/16-12	UNC	,500	,25	,07	,572	,516	,56	9/16-12	.0041	15/32	3/16
TR1665.81305	SL	7/16-14	UNC	5/8-11	UNC	,625	,28	,10	,635	,578	,68	5/8-11	.0050	17/32	3/16
TR1665.81505	SL	7/16-20	UNF	5/8-11	UNC	,625	,28	,10	,635	,578	,68	5/8-11	.0051	17/32	3/16
TR1665.81306	SL	1/2-13	UNC	11/16-11NS	UNS	,688	,28	,10	,700	,641	,75	11/16-11NS	.0060	19/32	3/16
TR1665.81506	SL	1/2-20	UNF	11/16-11NS	UNS	,688	,28	,10	,700	,641	,75	11/16-11NS	.0061	19/32	3/16
TR1665.81307	SL	9/16-12	UNC	13/16-16	UN	,812	,32	,10	,822	,766	,94	13/16-16	.0070	23/32	3/16
TR1665.81507	SL	9/16-12	UNF	13/16-16	UN	,812	,32	,10	,885	,766	,94	13/16-16	.0071	23/32	3/16
TR1665.81308	SL	5/8-11	UNC	7/8-14	UNF	,875	,33	,10	,885	,828	1,00	7/8-14	.0080	25/32	3/16
TR1665.81508	SL	5/8-18	UNF	7/8-14	UNF	,875	,33	,10	,885	,828	1,00	7/8-14	.0081	25/32	3/16
TR1665.81309	SL	3/4-10	UNC	1-1/8-12	UNF	1,250	,49	,10	1,145	1,062	1,44	1-1/8-12	.0090	31/32	5/16
TR1665.81509	SL	3/4-16	UNF	1-1/8-12	UNF	1,250	,49	,10	1,145	1,062	1,44	1-1/8-12	.0091	31/32	5/16
TR1665.81310	SL	7/8-9	UNC	1-1/4-12	UNF	1,375	,49	,10	1,270	1,187	1,56	1-1/4-12	.0100	1-3/32	5/16
TR1665.81510	SL	7/8-14	UNF	1-1/4-12	UNF	1,375	,49	,10	1,270	1,187	1,56	1-1/4-12	.0101	1-3/32	5/16
TR1665.81311	SL	1-8	UNC	1-3/8-12	UNF	1,500	,55	,10	1,395	1,312	1,68	1-3/8-12	.0110	1-7/32	5/16



Threaded Insert MS/NAS - H Duty - 4140 steel - self-locking - MS/NAS grade



Order No.	Type	d ₁ class 3B	Thread type d ₁	d ₂ (mod.) class 2A	Thread type d ₂	l ₁	l ₃ ±0.0 c'bore 30	l ₄ depth	Inst. c'sink hole size +0.010 - 0.000	Inst. tap drill size	Inst. thread tap depth min.	Inst. thread tap size class 2B	Inst. tool ref. TR1705	Removal drill size	Removal drill depth
TR1665.81511	SL	1-12	UNF	1-3/8-12	UNF	1,500	,55	,10	1,395	1,312	1,68	1-3/8-12	.0111	1-7/32	5/16

THREADED INSERTS STEEL



TR1666

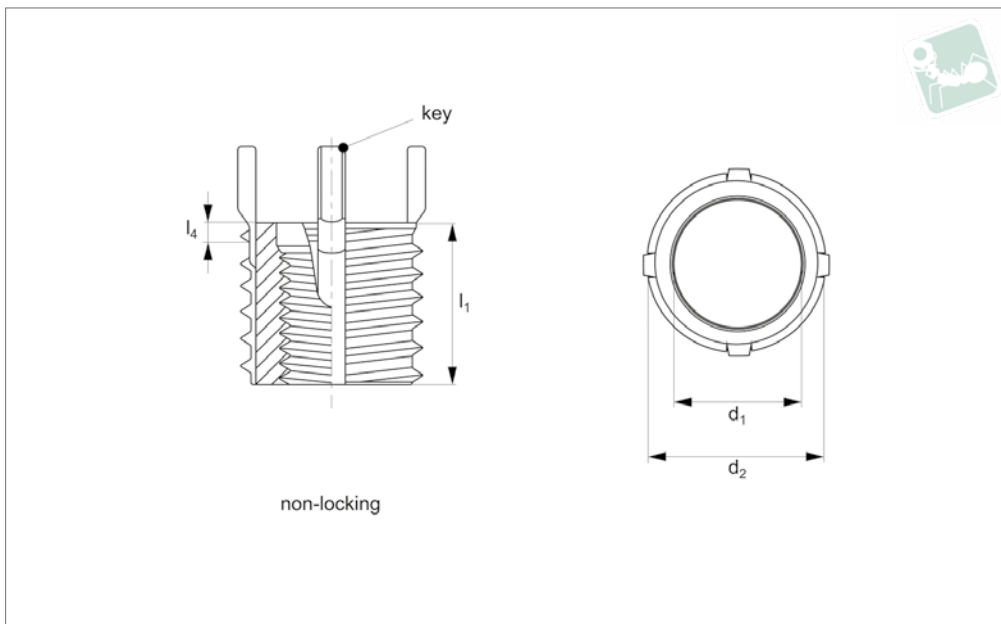

Material

Inserts - 4140 alloy steel (160 KSI Min).
 Keys - 302 CRES.
 Cadmium plate (QQ-P-416 Type II, Cl. 2).
 Dry film lubricatoin on self-locking inserts only.

Technical Notes

All dimensions in inches.
 Internal threads: to SAE AS8879.
 General tolerances -

+/- 0,010 unless specified.
 Tap drill hole tolerances -
 0,234 to 0,500 = +0,004/-0,001
 0,500 and over = +0,005/-0,001
NL = Non-Locking type.

Tips

Order installation tool separately, as identified by „Inst. Tool ref.“ in table.

Important Notes

Four locking keys on internal threads 1/4

and over. Two locking keys on internal threads smaller than 1/4.
 Installation (Inst.) drill size, counter sink, thread tap and thread depth as specified in table.
 Removal (Rem.) drill size and drill depth as specified in table.
 Perform to standards: MIL-I-45914A (MS51832)

Order No.	Type	d ₁ class 3B	Thread type d ₁	d ₂ (mod.) class 2A	Thread type d ₂	l ₁	l ₄ c'bore depth	Inst. c'sink hole size +0.010 - 0.000	Inst. tap drill size	Inst. thread tap depth min.	Inst. thread tap size class 2B	Inst. tool ref. TR1706	Removal drill size	Removal drill depth
TR1666.80333	NL	10-24	UNC	7/16-14	UNC	,312	,07	,447	,397	,37	7/16-14	.0330	11/32	3/16
TR1666.80533	NL	10-32	UNF	7/16-14	UNC	,312	,07	,447	,397	,37	7/16-14	.0331	11/32	3/16
TR1666.80334	NL	1/4-20	UNC	1/2-13	UNC	,375	,07	,510	,453	,44	1/2-13	.0340	13/32	3/16
TR1666.80534	NL	1/4-28	UNF	1/2-13	UNC	,375	,07	,510	,453	,44	1/2-13	.0341	13/32	3/16
TR1666.80335	NL	5/16-18	UNC	9/16-12	UNC	,437	,07	,572	,516	,50	9/16-12	.0350	15/32	3/16
TR1666.80535	NL	5/16-24	UNF	9/16-12	UNC	,437	,07	,572	,516	,50	9/16-12	.0351	15/32	3/16
TR1666.80336	NL	3/8-16	UNC	5/8-11	UNC	,500	,07	,635	,578	,56	5/8-11	.0360	17/32	3/16
TR1666.80536	NL	3/8-24	UNF	5/8-11	UNC	,500	,07	,635	,578	,56	5/8-11	.0361	17/32	3/16
TR1666.80337	NL	7/16-14	UNC	11/16-11NS	UNS	,625	,10	,700	,641	,68	11/16-11NS	.0370	19/32	3/16
TR1666.80537	NL	7/16-20	UNF	11/16-11NS	UNS	,625	,10	,700	,641	,68	11/16-11NS	.0371	19/32	3/16
TR1666.80338	NL	1/2-13	UNC	13/16-16	UN	,688	,10	,822	,766	,75	13/16-16	.0380	23/32	3/16
TR1666.80538	NL	1/2-20	UNF	13/16-16	UN	,688	,10	,822	,766	,75	13/16-16	.0381	23/32	3/16
TR1666.80339	NL	9/16-12	UNC	7/8-14	UNF	,812	,10	,885	,828	,94	7/8-14	.0390	25/32	3/16
TR1666.80539	NL	9/16-18	UNF	7/8-14	UNF	,812	,10	,885	,828	,94	7/8-14	.0391	25/32	3/16
TR1666.80340	NL	5/8-11	UNC	1"-12	UNF	,875	,10	1,020	,937	1,00	1"-12	.0400	27/32	3/16
TR1666.80540	NL	5/8-18	UNF	1"-12	UNF	,875	,10	1,020	,937	1,00	1"-12	.0401	27/32	5/16
TR1666.80341	NL	3/4-10	UNC	1-1/4-12	UNF	1,125	,10	1,270	1.187	1,31	1-1/4-12	.0410	1-3/32	5/16
TR1666.80541	NL	3/4-16	UNF	1-1/4-12	UNF	1,125	,10	1,270	1.187	1,31	1-1/4-12	.0411	1-3/32	5/16
TR1666.80342	NL	7/8-9	UNC	1-3/8-12	UNF	1,250	,10	1,395	1,312	1,44	1-3/8-12	.0420	1-7/32	5/16
TR1666.80542	NL	7/8-14	UNF	1-3/8-12	UNF	1,250	,10	1,395	1,312	1,44	1-3/8-12	.0421	1-7/32	5/16
TR1666.80343	NL	1-8	UNC	1-1/2-12	UNF	1,375	,10	1,520	1,437	1,56	1-1/2-12	.0430	1-11/32	5/16
TR1666.80543	NL	1-12	UNF	1-1/2-12	UNF	1,375	,10	1,520	1,437	1,56	1-1/2-12	.0431	1-11/32	5/16



Threaded Insert MS/NAS - Extra H

4140 steel - self-locking - MS/NAS grade

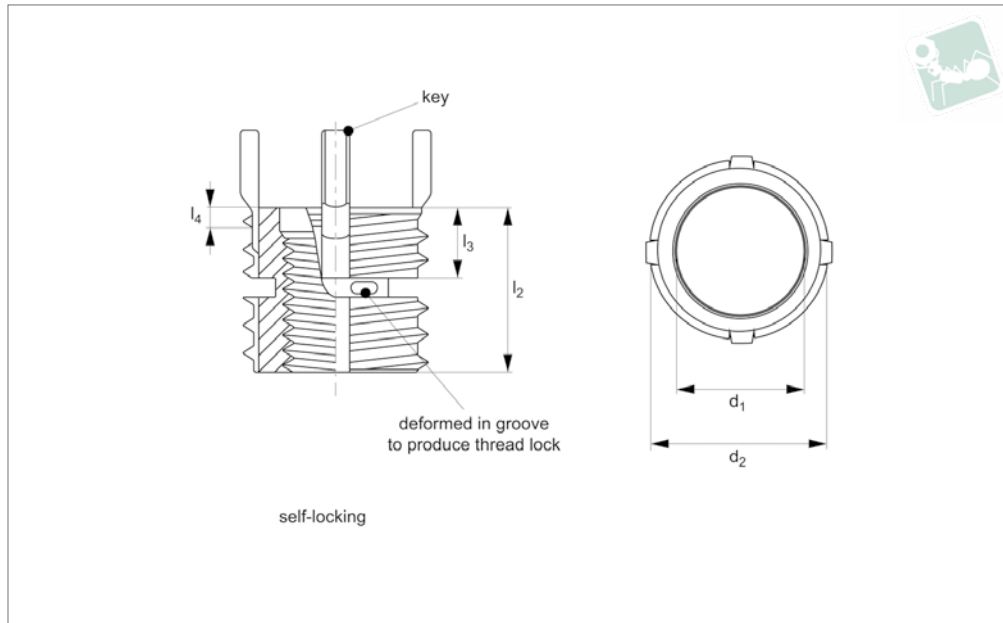
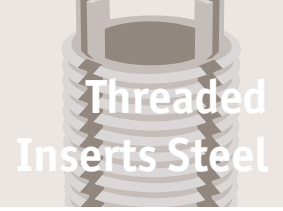

TR1667

THREADED INSERTS STEEL

Material

Inserts - 4140 alloy steel (160 KSI Min).
 Keys - 302 CRES.
 Cadmium plate (QQ-P-416 Type II, Cl. 2).
 Dry film lubrication on self-locking inserts only.

Technical Notes

All dimensions in inches.
 Internal threads: to SAE AS8879.
 General tolerances -

+/- 0,010 unless specified.

Tap drill hole tolerances -
 0,234 to 0,500 = +0,004/-0,001
 0,500 and over = +0,005/-0,001

SL = Self-Locking type, deliberate deformity in thread produces self-affect once installed (see technical diagram).

Tips

Order installation tool separately, as identified by „Inst. Tool ref.“ in table.

Important Notes

Four locking keys on internal threads 1/4 and over. Two locking keys on internal threads smaller than 1/4.
 Installation (Inst.) drill size, counter sink, thread tap and thread depth as specified in table.
 Removal (Rem.) drill size and drill depth as specified in table.
 Perform to standards: MIL-I-45914A (MS51832)

Order No.	Type	d ₁	Thread type d ₁	d ₂	Thread type d ₂	l ₁	l ₃
TR1667.81333	SL	10-24	UNC	7/16-14	UNC	,312	,22
TR1667.81533	SL	10-32	UNF	7/16-14	UNC	,312	,22
TR1667.81334	SL	1/4-20	UNC	1/2-13	UNC	,375	,22
TR1667.81534	SL	1/4-28	UNF	1/2-13	UNC	,375	,22
TR1667.81335	SL	5/16-18	UNC	9/16-12	UNC	,437	,22
TR1667.81535	SL	5/16-24	UNF	9/16-12	UNC	,437	,22
TR1667.81336	SL	3/8-16	UNC	5/8-11	UNC	,500	,25
TR1667.81536	SL	3/8-24	UNF	5/8-11	UNC	,500	,25
TR1667.81337	SL	7/16-14	UNC	11/16-11NS	UNS	,625	,28
TR1667.81537	SL	7/16-20	UNF	11/16-11NS	UNS	,625	,28
TR1667.81338	SL	1/2-13	UNC	13/16-16	UN	,688	,28
TR1667.81538	SL	1/2-20	UNF	13/16-16	UN	,688	,28
TR1667.81339	SL	9/16-12	UNC	7/8-14	UNF	,812	,32
TR1667.81539	SL	9/16-18	UNF	7/8-14	UNF	,812	,32
TR1667.81340	SL	5/8-11	UNC	1-12	UNF	,875	,33
TR1667.81540	SL	5/8-18	UNF	1-12	UNF	,875	,33
TR1667.81341	SL	3/4-10	UNC	1-1/4-12	UNF	1.250	,49
TR1667.81541	SL	3/4-16	UNF	1-1/4-12	UNF	1.250	,49
TR1667.81342	SL	7/8-9	UNC	1-3/8-12	UNF	1.375	,49
TR1667.81542	SL	7/8-14	UNF	1-3/8-12	UNF	1.375	,49
TR1667.81343	SL	1-8	UNC	1-1/2-12	UNF	1.500	,55
TR1667.81543	SL	1-12	UNF	1-1/2-12	UNF	1.500	,55

Order No.	l ₄ c'bore depth	Inst. c'sink hole size	Inst. tap drill size	Inst. thread tap depth	Inst. thread tap size	Inst. tool ref. TR1706	Removal drill size	Removal drill depth
TR1667.81333	,07	,447	,397	,37	7/16-14	.0330	11/32	3/16



Order No.	I ₄ c'bore depth	Inst. c'sink hole size	Inst. tap drill size	Inst. thread tap depth	Inst. thread tap size	Inst. tool ref. TR1706	Removal drill size	Removal drill depth
TR1667.81533	,07	,447	,397	,37	7/16-14	.0331	11/32	3/16
TR1667.81334	,07	,510	,453	,44	1/2-13	.0340	13/32	3/16
TR1667.81534	,07	,510	,453	,44	1/2-13	.0341	13/32	3/16
TR1667.81335	,07	,572	,516	,50	9/16-12	.0350	15/32	3/16
TR1667.81535	,07	,572	,516	,50	9/16-12	.0351	15/32	3/16
TR1667.81336	,07	,635	,578	,56	5/8-11	.0360	17/32	3/16
TR1667.81536	,07	,635	,578	,56	5/8-11	.0361	17/32	3/16
TR1667.81337	,10	,700	,641	,68	11/16-11NS	.0370	19/32	3/16
TR1667.81537	,10	,700	,641	,68	11/16-11NS	.0371	19/32	3/16
TR1667.81338	,10	,822	,766	,75	13/16-16	.0380	23/32	3/16
TR1667.81538	,10	,822	,766	,75	13/16-16	.0381	23/32	3/16
TR1667.81339	,10	,885	,828	,94	7/8-14	.0390	25/32	3/16
TR1667.81539	,10	,885	,828	,94	7/8-14	.0391	25/32	3/16
TR1667.81340	,10	1.020	,937	1.00	1-12	.0400	27/32	5/16
TR1667.81540	,10	1.020	,937	1.00	1-12	.0401	27/32	5/16
TR1667.81341	,10	1.270	1.187	1.44	1-1/4-12	.0410	1-3/32	5/16
TR1667.81541	,10	1.270	1.187	1.44	1-1/4-12	.0411	1-3/32	5/16
TR1667.81342	,10	1.395	1.312	1.56	1-3/8-12	.0420	1-7/32	5/16
TR1667.81542	,10	1.395	1.312	1.56	1-3/8-12	.0421	1-7/32	5/16
TR1667.81343	,10	1.520	1.437	1.68	1-1/2-12	.0430	1-11/32	5/16
TR1667.81543	,10	1.520	1.437	1.68	1-1/2-12	.0431	1-11/32	5/16



Threaded Insert - Solid - Metric

carbon steel

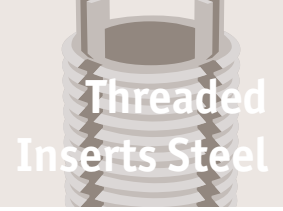

TR1692

THREADED INSERTS STEEL

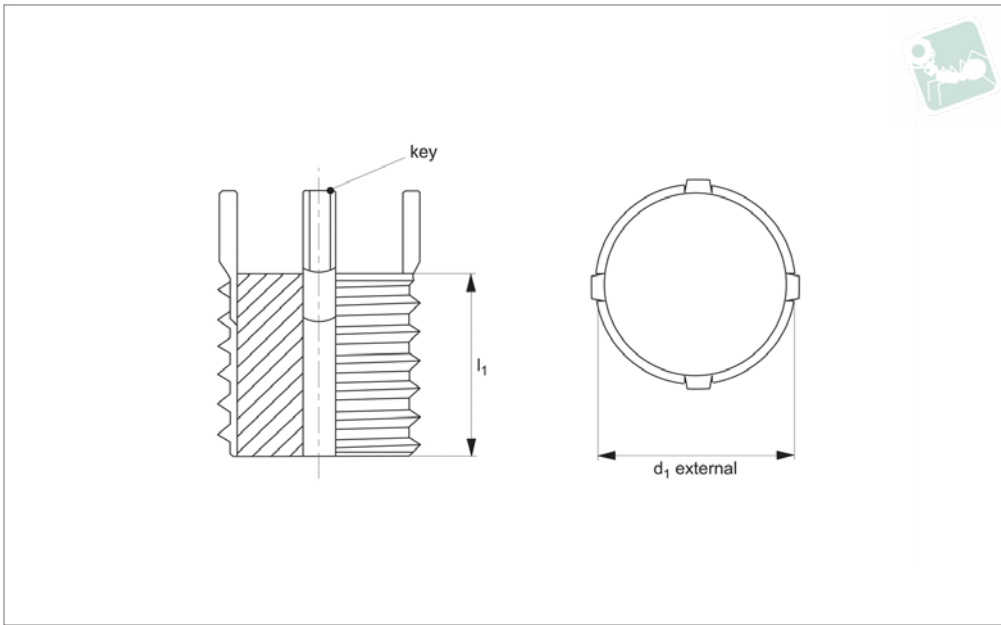

Material

Inserts: carbon steel (C1215) or equivalent. Zinc phosphate.

Keys: stainless steel (302 CRES) or equivalent. Passivated.

Technical Notes

General tolerances:

± 0,25" unless specified.

Tap drill hole tolerances:

6,9 to 10,8 = +0,10/-0,025".
12,8 and over = +0,13/-0,025".

Tips

Order installation tool separately, as identified by „Inst. tool ref.“ in table.

Important Notes

Four locking keys on external threads M12 and over. Two locking keys on external

threads smaller than M12.

Installation (Inst.) drill size, countersink, thread tap and thread depth as specified in table.

Removal drill size and drill depth as specified in table.

External metric thread allows you to machine your internal thread.

Order No.	d ₁ tol. 6g	Thread type d ₁	l ₁	Inst. tool ref. 22052	Inst. tap drill size	Inst. c'sink dia. +0.25 -0.00	Inst. thread tap tol. 6H	Inst. thread depth min.	Removal drill size	Removal drill depth
TR1692.66021	M 8x1,25	Coarse	8	.W0210	6,90	8,3	M 8x1,25	9,5	5,5	4,0
TR1692.66022	M10x1,25	Fine	10	.W0220	8,80	10,3	M10x1,25	12,5	7,5	4,8
TR1692.66023	M12x1,25	Fine	12	.W0230	10,80	12,3	M12x1,25	14,5	9,5	4,8
TR1692.66024	M14x1,50	Fine	14	.W0240	12,80	14,3	M14x1,50	16,5	11,5	4,8
TR1692.66025	M16x1,50	Fine	16	.W0250	14,75	16,3	M16x1,50	18,5	13,5	4,8
TR1692.66026	M18x1,50	Fine	18	.W0260	16,75	18,3	M18x1,50	20,5	15,5	4,8
TR1692.66027	M20x1,50	Fine	20	.W0270	18,75	20,3	M20x1,50	22,5	17,5	4,8
TR1692.66028	M22x1,50	Fine	22	.W0280	20,50	22,3	M22x1,50	24,5	17,8	6,4
TR1692.66029	M24x1,50	Fine	24	.W0290	22,50	24,3	M24x1,50	26,5	19,8	6,4
TR1692.66030	M30x2,00	Fine	30	.W0300	28,00	30,3	M30x2,00	34,5	25,8	6,4
TR1692.66031	M32x2,00	Non-Std	32	.W0310	30,00	32,3	M32x2,00	36,5	27,8	6,4
TR1692.66032	M33x2,00	Non-Std	33	.W0320	31,00	33,3	M33x2,00	37,5	28,8	6,4



TR1698

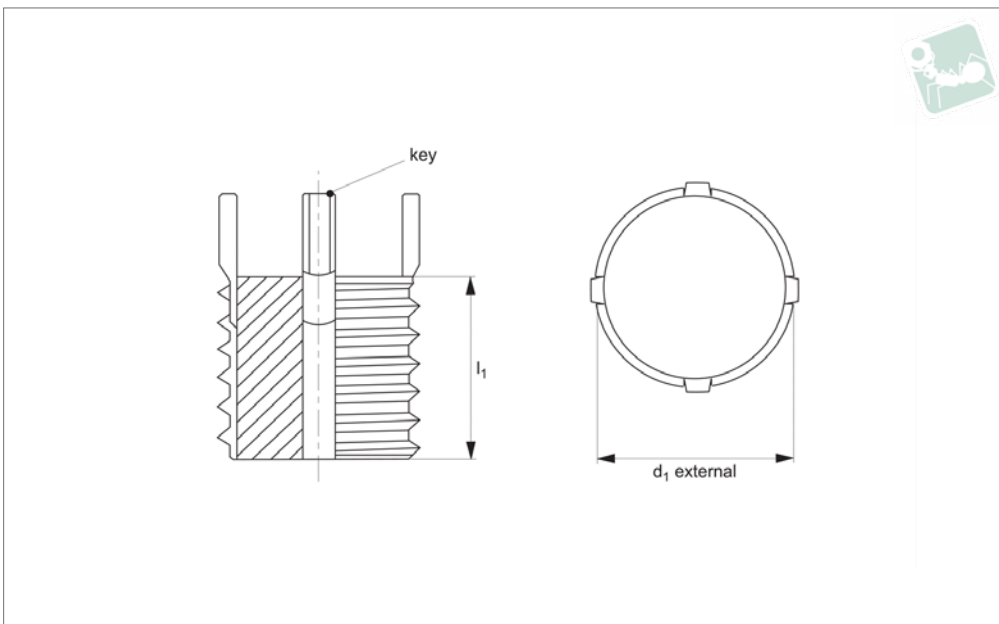

Material

Inserts: carbon steel (C1215) or equivalent. Zinc phosphate.

Keys: stainless steel (302 CRES) or equivalent. Passivated.

Technical Notes

General tolerances:

± 0,010" unless specified.

Tap drill hole tolerances:

0,234 to 0,500 = +0,004/-0,001"
0,500 and over = +0,005/-0,001"

Tips

Order installation tool separately, as identified by „Inst. tool ref.“ in table.

Important Notes

Four locking keys on external threads 7/16" and over. Two locking keys on

external threads smaller than 7/16".

Installation (Inst.) drill size, countersink, thread tap and thread depth as specified in table.

Removal drill size and drill depth as specified in table.

External inch thread allows you to machine your internal thread.

All dimensions in inches.

Order No.	d ₁ (mod.) tol. 2A	Thread type d ₁	l ₁	Inst. tool ref. 22050	Inst. tap drill size	Inst. c'sink dia. +0.010 - 0.000	Inst. thread tap tol. 2B	Inst. thread tap depth min.	Removal drill size	Removal drill depth
TR1698.66001	5/16"-18	UNC	0,31	.W0010	0,27	0,32	5/16"-18	0,37	7/32"	1/8"
TR1698.66002	3/8"-16	UNC	0,31	.W0020	0,33	0,38	3/8"-16	0,37	9/32"	1/8"
TR1698.66003	7/16"-14	UNC	0,37	.W0030	0,40	0,44	7/16"-14	0,43	11/32"	3/16"
TR1698.66004	1/2"-13	UNC	0,43	.W0040	0,45	0,51	1/2"-13	0,50	13/32"	3/16"
TR1698.66005	9/16"-12	UNC	0,50	.W0050	0,52	0,57	9/16"-12	0,56	15/32"	3/16"
TR1698.66006	5/8"-11	UNC	0,62	.W0060	0,58	0,63	5/8"-11	0,68	17/32"	3/16"
TR1698.66007	3/4"-16	UNF	0,68	.W0070	0,70	0,76	3/4"-16	0,75	21/32"	3/16"
TR1698.66008	7/8"-14	UNF	0,87	.W0080	0,83	0,88	7/8"-14	1,00	25/32"	5/16"
TR1698.66009	1"-12	UNF	0,87	.W0090	0,94	1,02	1"-12	1,00	27/32"	5/16"
TR1698.66010	1-1/8"-12	UNF	1,12	.W0100	1,06	1,14	1-1/8"-12	1,31	31/32"	5/16"
TR1698.66011	1-1/4"-12	UNF	1,25	.W0110	1,19	1,27	1-1/4"-12	1,44	1-3/32"	5/16"
TR1698.66012	1-3/8"-12	UNF	1,37	.W0120	1,31	1,39	1-3/8"-12	1,56	1-7/32"	5/16"