

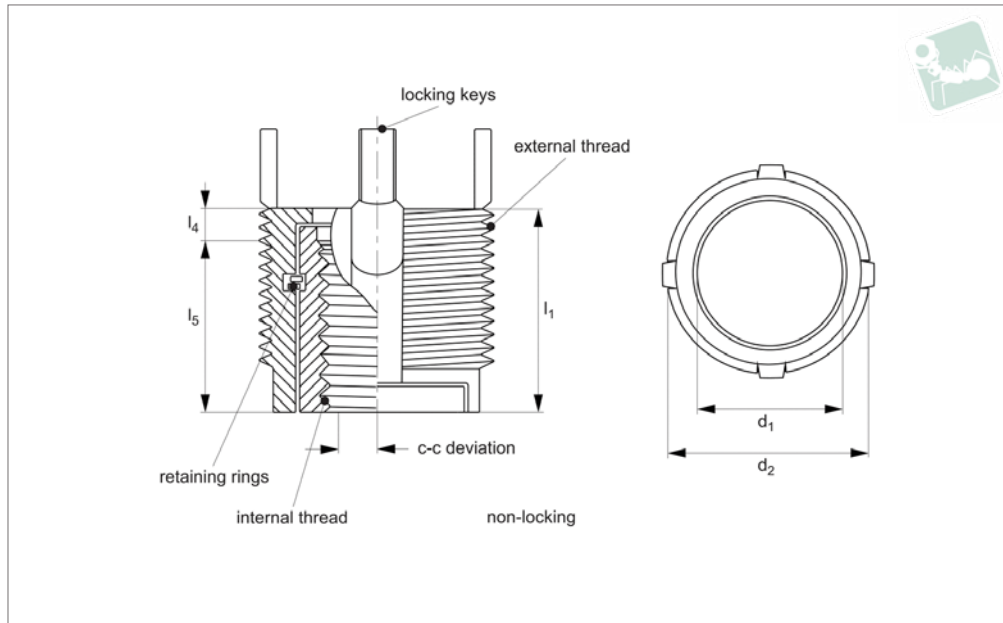

# Floating Threaded Insert - H Duty - 4140 steel - self-locking

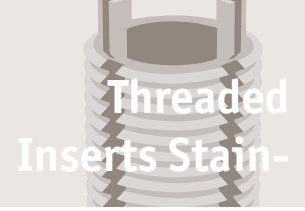

**TR1686**

THREADED INSERTS STAINLESS

### Material

Inserts - 4140 alloy steel (160 KSI Min).  
Keys - 302 CRES.  
Cadmium plate (QQ-P-416 Type II, Cl. 2).  
Dry film lubrication on self-locking inserts only.

### Technical Notes

All dimensions in inches.  
Internal threads: to SAE AS8879.  
General tolerances -

+/- 0,010 unless specified.

Tap drill hole tolerances -  
0,130 to 0,233 = +0,003/-0,001

**SL** = Self-Locking type, deliberate deformity in thread produces self-affect once installed (see technical diagram).

### Tips

Order installation tool separately, as identified by „Inst. Tool ref.“ in table.

### Important Notes

Four locking keys on internal threads 5/16 and over. Two locking keys on internal threads smaller than 5/16.

Installation (Inst.) drill size, counter sink, thread tap and thread depth as specified in table.

Removal (Rem.) drill size and drill depth as specified in table.

Perform to standards:

Order No.	Type	d <sub>1</sub> tol. 3B	Thread type d <sub>1</sub>	l <sub>1</sub> ±0.0 15	d <sub>2</sub> (mod.) class 2A	Thread type d <sub>2</sub>	l <sub>4</sub>	l <sub>5</sub>	c-c float min.	Inst. c'sink dia. +0.010  -0.000	Inst. tap drill size	Inst. thread tap depth min.	Inst. thread tap size class 2B	Inst. tool ref. TR1725	Removal drill size	Removal drill depth
TR1686.89501	SL	10-24	UNC	,40	7/16-20	UNC	,15	,25	,040	,447	,406	,39	7/16-20	.0010	11/32	5/32
TR1686.89601	SL	10-32	UNF	,40	7/16-20	UNC	,15	,25	,040	,447	,406	,39	7/16-20	.0010	11/32	5/32
TR1686.89502	SL	1/4-20	UNC	,40	1/2-20	UNF	,15	,25	,040	,510	,486	,39	1/2-20	.0020	13/32	5/32
TR1686.89602	SL	1/4-28	UNF	,40	1/2-20	UNF	,15	,25	,040	,510	,486	,39	1/2-20	.0020	13/32	5/32
TR1686.89503	SL	5/16-18	UNC	,53	5/8-18	UNF	,13	,39	,040	,635	,578	,50	5/8-18	.0030	17/32	3/16
TR1686.89603	SL	5/16-24	UNF	,53	5/8-18	UNF	,13	,39	,040	,635	,578	,50	5/8-18	.0030	17/32	3/16
TR1686.89504	SL	3/8-16	UNC	,65	3/4-16	UNF	,20	,45	,040	,760	,703	,62	3/4-16	.0040	21/32	3/16
TR1686.89604	SL	3/8-24	UNF	,65	3/4-16	UNF	,20	,45	,040	,760	,703	,62	3/4-16	.0040	21/32	3/16
TR1686.89505	SL	7/16-14	UNC	,67	7/8-14	UNF	,20	,45	,040	,885	,828	,62	7/8-14	.0050	25/32	3/16
TR1686.89605	SL	7/16-20	UNF	,67	7/8-14	UNF	,20	,45	,040	,885	,828	,62	7/8-14	.0050	25/32	3/16
TR1686.89506	SL	1/2-13	UNC	,73	1-12	UNF	,23	,50	,040	1,020	,937	,65	1-12	.0060	27/32	5/16
TR1686.89606	SL	1/2-20	UNF	,73	1-12	UNF	,23	,50	,040	1,020	,937	,65	1-12	.0060	27/32	5/16