

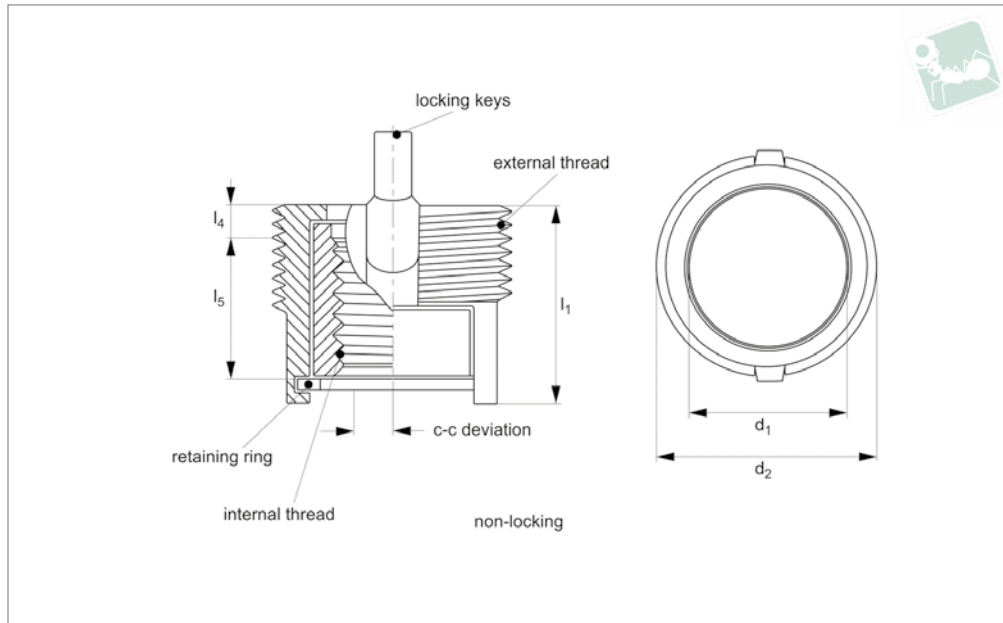

# Floating Threaded Insert - Mini - Inch

303 stainless steel - self-locking



**TR1681**

THREADED INSERTS STAINLESS

**Material**

Inserts - 303 CRES.  
 Keys and retaining ring - 302 CRES.  
 Passivated. Dry film lubrication on self-locking inserts only.

**Technical Notes**

All dimensions in inches.  
 Internal threads: to SAE AS8879.  
 General tolerances -  
 +/- 0,010 unless specified.

Tap drill hole tolerances -

0,130 to 0,233 = +0,003/-0,001  
**SL** = Self-Locking type, deliberate deformity in thread produces self-affect once installed (see technical diagram).

**Tips**

Order installation tool separately, as identified by „Inst. Tool ref.“ in table.

**Important Notes**

Four locking keys on internal threads 5/16 and over. Two locking keys on internal threads smaller than 5/16.  
 Installation (Inst.) drill size, counter sink, thread tap and thread depth as specified in table.  
 Removal (Rem.) drill size and drill depth as specified in table.  
 Perform to standards

Order No.	Type	d <sub>1</sub> tol. 3B	Thread type d <sub>1</sub>	l <sub>1</sub> ±0.01 5	d <sub>2</sub> tol. 2A	Thread type d <sub>2</sub>	l <sub>4</sub>	l <sub>5</sub>	c-c float	Inst. c'sink dia. +0.01 0 - 0.000	Inst. tap drill size	Inst. thread tap depth min.	Inst. thread tap size class 2B	Inst. tool ref. TR1720	Removal drill size	Removal drill depth
<b>TR1681.87583</b>	SL	2-56	UNC	,19	1/4-28	UNF	,05	,10	,015	,250	,228	,12	1/4-28	.0830	#8	3/32
<b>TR1681.87584</b>	SL	4-40	UNC	,32	5/16-24	UNF	,07	,21	,020	,323	,272	,31	5/16-24	.0840	7/32	1/8
<b>TR1681.87585</b>	SL	6-32	UNC	,36	3/8-24	UNF	,08	,22	,030	,385	,332	,38	3/8-24	.0850	9/32	1/8
<b>TR1681.87586</b>	SL	8-32	UNC	,36	3/8-24	UNF	,08	,22	,030	,385	,332	,38	3/8-24	.0860	9/32	1/8