

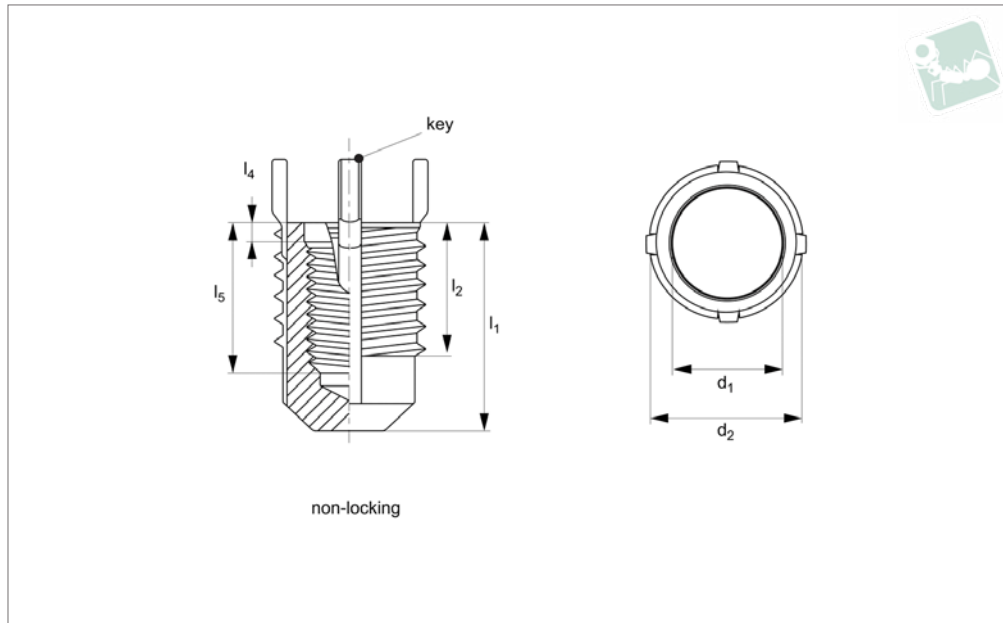

# Blind Threaded Insert - Mini - Inch

303 stainless steel - non-locking



**TR1670**

THREADED INSERTS STAINLESS

**Material**

Inserts - A303 CRES.  
Keys - 302 CRES.  
Passivated. Dry film lubrication on self-locking inserts only.

**Technical Notes**

All dimensions in inches.  
Internal threads: to SAE AS8879.  
General tolerances -  
+/- 0,010 unless specified.

Tap drill hole tolerances -  
0,234 to 0,500 = +0,004/-0,001  
0,500 and over = +0,005/-0,001  
**NL** = Non-Locking type.

**Tips**

Order installation tool separately, as identified by „Inst. Tool ref.“ in table.

**Important Notes**

Four locking keys on internal threads 5/16

and over. Two locking keys on internal threads smaller than 5/16.  
Installation (Inst.) drill size, counter sink, thread tap and thread depth as specified in table.  
Removal (Rem.) drill size and drill depth as specified in table.  
Perform to standards: MIL-I-45914A

Order No.	Type	d <sub>1</sub> tol. 3B	Thre ad type d <sub>1</sub>	d <sub>2</sub> tol. 2A	Thre ad type d <sub>2</sub>	l <sub>1</sub>	l <sub>2</sub>	l <sub>4</sub> c'bore depth	l <sub>5</sub>	Inst. c'sink hole size +0.010  -0.000	Inst. tap drill size	Inst. thread tap depth min.	Inst. thread tap size class 2B	Inst. tool ref. TR1700	Remo val drill size	Removal drill depth
TR1670.83290	NL	2-56	UNC	8-32	UNC	,24	,18	C'Sin k	,13	,166	,134	,24	8-32	.0830	#33	1/16
TR1670.83291	NL	4-40	UNC	10-32	UNF	,31	,22	C'Sin k	,17	,194	.161	,28	10-32	.0840	#29	3/32
TR1670.83292	NL	6-32	UNC	12-28	UNF	,39	,22	C'Sin k	,21	,220	,187	,28	12-28	.0850	#21	3/32
TR1670.83294	NL	8-32	UNC	1/4-28	UNF	,43	,24	C'Sin k	,25	,255	,228	,30	1/4-28	.0860	#8	3/32