

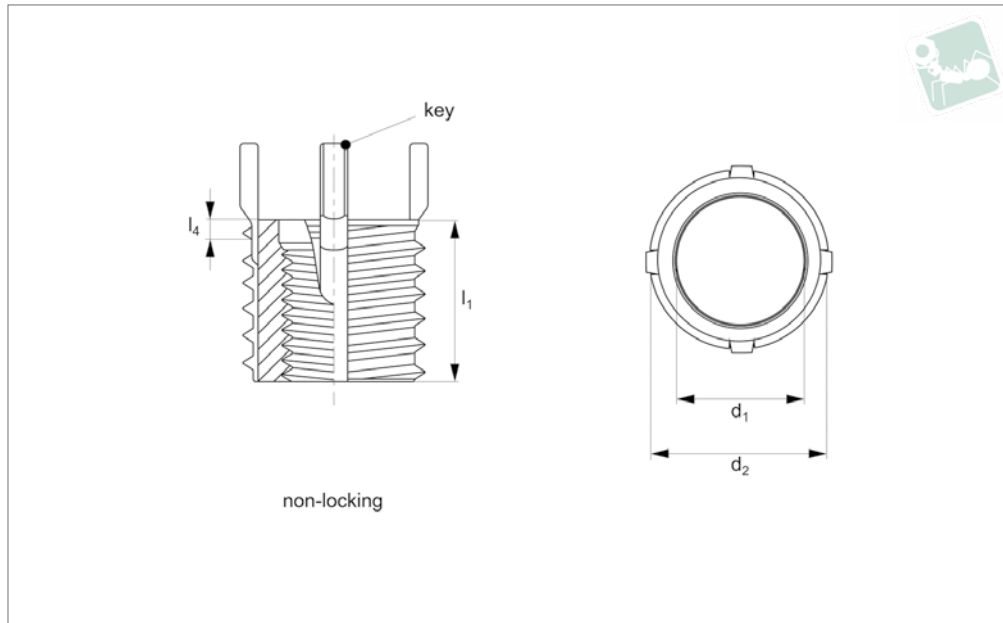

Threaded Insert MS/NAS - H Duty - 303 stainless steel - non-locking - MS/NAS grade



TR1654

THREADED INSERTS STAINLESS

Material

Inserts - 303 CRES.
Keys - 302 CRES.
Passivated. Dry film lubrication on self-locking inserts only.

Technical Notes

All dimensions in inches.
Internal threads: to SAE AS8879.
General tolerances -
+/- 0,010 unless specified.

Tap drill hole tolerances -
0,234 to 0,500 = +0,004/-0,001
0,500 and over = +0,005/-0,001
NL = Non-Locking type.

Tips

Order installation tool separately, as identified by „Inst. Tool ref.“ in table.

Important Notes

Four locking keys on internal threads 5/16

and over. Two locking keys on internal threads smaller than 5/16.
Installation (Inst.) drill size, counter sink, thread tap and thread depth as specified in table.
Removal (Rem.) drill size and drill depth as specified in table.
Perform to standards: MIL-I-45914A (MS51830 & NAS1394)

Order No.	Type	d ₁ tol. 3B	Thread type d ₁	d ₂ (mod.) class 2A	Thread type d ₂	l ₁	l ₄ c'bore depth	Inst. c'sink hole size +0.010 - 0.000	Inst. tap drill size	Inst. thread tap depth min.	Inst. thread tap size class B	Inst. tool ref. TR1705	Removal drill size	Removal drill depth
TR1654.76300	NL	8-32	UNC	5/16-18	UNC	,312	,04	,323	,272	,37	5/16-18	.0000	7/32	1/8
TR1654.76301	NL	10-24	UNC	3/8-16	UNC	,312	,07	,385	,332	,37	3/8-16	.0010	9/32	1/8
TR1654.76501	NL	10-32	UNF	3/8-16	UNC	,312	,07	,385	,332	,37	3/8-16	.0011	9/32	1/8
TR1654.76302	NL	1/4-20	UNC	7/16-14	UNC	,375	,07	,447	,397	,43	7/16-14	.0020	11/32	3/16
TR1654.76502	NL	1/4-28	UNF	7/16-14	UNC	,375	,07	,447	,397	,43	7/16-14	.0021	11/32	3/16
TR1654.76303	NL	5/16-18	UNC	1/2-13	UNC	,437	,07	,510	,453	,50	1/2-13	.0030	13/32	3/16
TR1654.76503	NL	5/16-24	UNF	1/2-13	UNC	,437	,07	,510	,453	,50	1/2-13	.0031	13/32	3/16
TR1654.76304	NL	3/8-16	UNC	9/16-12	UNC	,500	,07	,572	,516	,56	9-16-12	.0040	15/32	3/16
TR1654.76504	NL	3/8-24	UNF	9/16-12	UNC	,500	,07	,572	,516	,56	9-16-12	.0041	15/32	3/16
TR1654.76305	NL	7/16-14	UNC	5/8-11	UNC	,625	,10	,635	,578	,68	5/8-11	.0050	17/32	3/16



Order No.	Type	d ₁ tol. 3B	Thread type d ₁	d ₂ (mod.) class 2A	Thread type d ₂	l ₁	l ₄ c'bore depth	Inst. c'sink hole size +0.010 - 0.000	Inst. tap drill size	Inst. thread tap depth min.	Inst. thread tap size class B	Inst. tool ref. TR1705	Removal drill size	Removal drill depth
TR1654.76505	NL	7/ 16- 20	UNF	5/8- 11	UNC	,625	,10	,635	,578	,68	5/8-11	.0051	17/32	3/16
TR1654.76306	NL	1/2- 13	UNC	11/ 16- 11NS	UNS	,688	,10	,700	,641	,75	11/16- 11NS	.0060	19/32	3/16
TR1654.76506	NL	1/2- 20	UNF	11/ 16- 11NS	UNS	,688	,10	,700	,641	,75	11/16- 11NS	.0061	19/32	3/16
TR1654.76307	NL	9/ 16- 12	UNC	13/ 16-16	UNF	,812	,10	,822	,766	,94	13/16-16	.0070	23/32	3/16
TR1654.76507	NL	9/ 16- 18	UNF	13/ 16-16	UNF	,812	,10	,822	,766	,94	13/16-16	.0071	23/32	3/16
TR1654.76308	NL	5/8- 11	UNC	7/8- 14	UNF	,875	,10	,885	,828	1.00	7/8-14	.0080	25/32	3/16
TR1654.76508	NL	5/8- 18	UNF	7/8- 14	UNF	,875	,10	,885	,828	1.00	7/8-14	.0081	25/32	3/16
TR1654.76309	NL	3/4- 10	UNC	1-1/ 8-12	UNF	1.12 5	,10	1.145	1.062	1.31	1-1/8-12	.0090	31/32	5/16
TR1654.76509	NL	3/4- 16	UNF	1-1/ 8-12	UNF	1.12 5	,10	1.145	1.062	1.31	1-1/8-12	.0091	31/32	5/16
TR1654.76310	NL	7/8- 9	UNC	1-1/ 4-12	UNF	1.25 0	,10	1.270	1.187	1.44	1-1/4-12	.0100	1-3/32	5/16
TR1654.76510	NL	7/8- 14	UNF	1-1/ 4-12	UNF	1.25 0	,10	1.270	1.187	1.44	1-1/4-12	.0101	1-3/32	5/16
TR1654.76311	NL	1-8	UNC	1-3/ 8-12	UNF	1.37 5	,10	1.395	1.312	1.56	1-3/8-12	.0110	1-7/32	5/16
TR1654.76511	NL	1-12	UNF	1-3/ 8-12	UNF	1.37 5	,10	1.395	1.312	1.56	1-3/8-12	.0111	1-7/32	5/16