

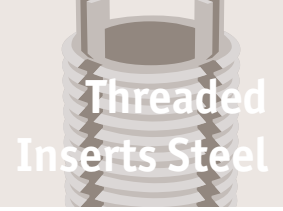

# Threaded Insert - Inch thinwall - carbon steel

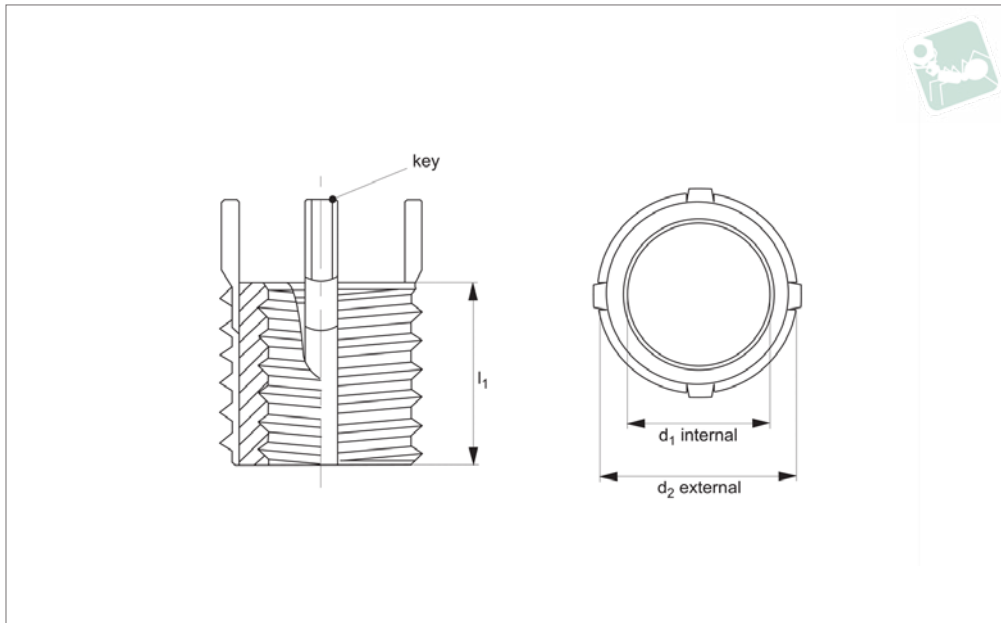

Threaded  
Inserts Steel



**TR1570**

THREADED INSERTS STEEL

### Material

Inserts: carbon steel (C1215) or equivalent. Zinc phosphate.

Keys: stainless steel (302 CRES) or equivalent. Passivated.

### Technical Notes

#### General tolerances:

± 0,010" unless specified.

#### Tap drill hole tolerances:

0,234 to 0,500 = +0,004/-0,001".

0,500 and over = +0,005/-0,001".

### Tips

Order installation tool separately, as identified by „Inst. tool ref.“ in table.

### Important Notes

Four locking keys on internal threads 5/16" and over. Two locking keys on internal

threads smaller than 5/16".

Installation (Inst.) drill size, countersink, thread tap and thread depth as specified in table.

Removal drill size and drill depth as specified in table.

**All dimensions in inches.**

Order No.	Int. d <sub>1</sub> tol. 2B	Int. thread type d <sub>1</sub>	Ext. d <sub>2</sub> tol. 2A	Ext. thread type d <sub>2</sub>	l <sub>1</sub>	Inst. tap drill size	Inst. tool ref. 22054	Inst. c'sink dia. +0.010 - 0.000	Inst. thread tap tol. 2B	Inst. thread depth min.	Removal drill size	Removal drill depth
TR1570.65921	10-24	UNC	5/16"-18	UNC	0,31	17/64"	.W0210	0,32	5/16"-18	0,37	7/32"	1/8"
TR1570.66121	10-32	UNF	5/16"-18	UNC	0,31	17/64"	.W0210	0,32	5/16"-18	0,37	7/32"	1/8"
TR1570.65922	1/4"-20	UNC	3/8"-16	UNC	0,37	21/64"	.W0220	0,38	3/8"-16	0,43	9/32"	3/16"
TR1570.66122	1/4"-28	UNF	3/8"-16	UNC	0,37	21/64"	.W0220	0,38	3/8"-16	0,43	9/32"	3/16"
TR1570.65923	5/16"-18	UNC	7/16"-14	UNC	0,43	25/64"	.W0230	0,44	7/16"-14	0,50	11/32"	3/16"
TR1570.66123	5/16"-24	UNF	7/16"-14	UNC	0,43	25/64"	.W0230	0,44	7/16"-14	0,50	11/32"	3/16"
TR1570.65924	3/8"-16	UNC	1/2"-13	UNC	0,50	29/64"	.W0240	0,51	1/2"-13	0,56	13/32"	3/16"
TR1570.66124	3/8"-24	UNF	1/2"-13	UNC	0,50	29/64"	.W0240	0,51	1/2"-13	0,56	13/32"	3/16"
TR1570.65925	7/16"-14	UNC	9/16"-12	UNC	0,56	33/64"	.W0250	0,57	9/16"-12	0,62	15/32"	3/16"
TR1570.66125	7/16"-20	UNF	9/16"-12	UNC	0,56	33/64"	.W0250	0,57	9/16"-12	0,62	15/32"	3/16"
TR1570.65926	1/2"-13	UNC	5/8"-11	UNC	0,62	37/64"	.W0260	0,63	5/8"-11	0,68	17/32"	3/16"
TR1570.66126	1/2"-20	UNF	5/8"-11	UNC	0,62	37/64"	.W0260	0,63	5/8"-11	0,68	17/32"	3/16"



Threaded inserts are used to quickly repair stripped, damaged or worn out threads with new stronger threads, or are used in original equipment to guarantee stronger thread connections.

Wixroyd inserts are easy to install and remove, without the need for special drills, taps or pre-winder tools. The 'locking keys' on threaded inserts are easily driven down into the thread of the surrounding base material – locking the insert securely in place.



Carbon steel inserts



Stainless steel inserts



Solid inserts

## Key Features

- Solid, one-piece construction providing high pull-out strengths.
- Locking "keys" provide a positive mechanical lock against rotation of the insert.
- Easy installation and removal.
- Installation with standard drills and taps.
- No pre-winder tools required.
- No tangs to break off and account for in the assembly.
- For use in a wide variety of materials.
- Both metric and imperial sizes available in coarse and fine pitches.

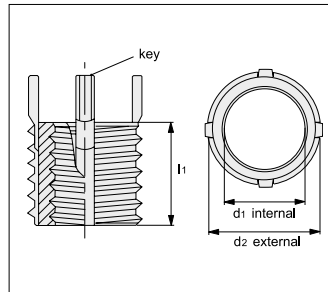

## Installation and Removal

### Installation

- 1 Select desired threaded insert, and from the product data table identify the installation drill and tap sizes (note the drill is slightly oversized deliberately). Drill with standard tap drill as per product data table, and countersink with standard 82-100° countersink.
- 2 Tap new threads with standard tap – as specified in product data table.
- 3 Screw in the insert until it is 0.25 to 0.75mm (0.010 to 0.030 inch) below the surface.
- 4 Drive locking keys down with several hammer taps on the installation tool – see product data table for correct tool.
- 5 Insert is installed.



### Removal

Wixroyd threaded inserts, can be removed (if required) without damage to the surrounding material.

- 1 Refer to product data tables to identify the drill size and drill depth required for removal. Drill out the material between the insert keys and the internal thread to specified depth.
- 2 Bend the locking keys inward and break off.
- 3 Remove the old insert using a screw extractor.
- 4 Install a replacement insert into the original tapped hole.

# Threaded Inserts

overview

22000 - 22064

Fixing Elements



**22000** - Thinwall - Metric  
Use installation tool  
no. 22060.



**22002** - Heavy Duty -  
Metric.  
Use installation tool  
no. 22062.



**22012** - Heavy Duty -  
Metric - Inch.  
Use installation tool  
no. 22064.



**22020, 22022, 22024** - Inch  
- Thinwall - Heavy Duty -  
Extra Heavy Duty.  
Use installation tool  
no. 22054-58.

## Stainless Steel



**22004** - Thinwall - Metric  
Use installation tool  
no. 22060.



**22006** - Heavy Duty -  
Metric  
Use installation tool  
no. 22062.



**22010** - Heavy Duty -  
Metric - Inch.  
Use installation tool  
no. 22064.



**22030 - 22034** - Inch  
- Thinwall - Heavy Duty -  
Extra Heavy Duty  
Use installation tool  
no. 22054, 20058.

## Carbon Steel



**22040** - Metric - Carbon  
Use installation tool  
no. 22052.



**22042** - Metric -  
Stainless Steel  
Use installation tool  
no. 22052.



**22044** - Inch - Carbon  
Use installation tool  
no. 22050.



**22046** - Inch - Stainless  
Steel  
Use installation tool  
no. 22050.

## Solid



**22050** for 22044 & 22046



**22052** for 22040 & 22042



**22054, 22058** for 22020,  
22024, 22030, 22034,



**22060** for 22000 & 22004

## Installation Tools



**22062** for 22002 & 22006



**22064** for 22010 & 22012

THREADED INSERTS STEEL