

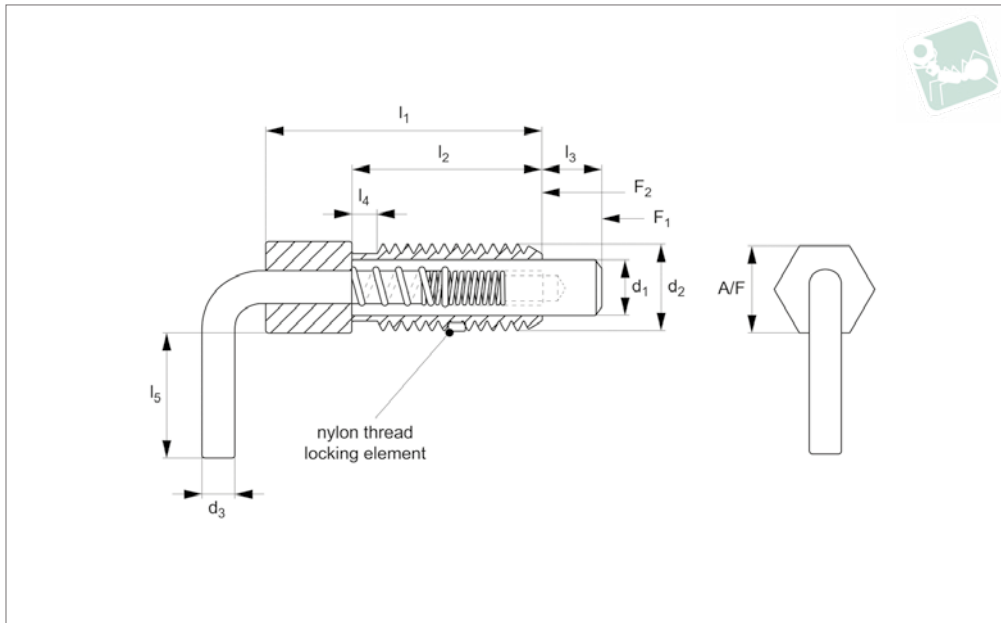

Spring Loaded Pin - Inch - Lever non-locking

Spring Loaded Pins



SL1116

SPRING LOADED PINS

Material

Body and pin: steel 12L14.

Technical Notes

Spring loaded pin is non-locking, pin

simply springs back when lever released.

A nylon locking element on thread reduces chance of loosening of thread due to vibration etc.

Tips

For suitable locknut, see part no. SL1816.

Order No.	d ₁	d ₂ UNC	l ₁	l ₂	l ₃	l ₄	l ₅	d ₃	A/F	Spring force f ₁ lb	Spring force f ₂ lb
SL1116.I25-016-C	0.16	1/4-20	1.25	0.80	0.38	-	0.50	0.09	0.25	0.50	2.50
SL1116.I37-025-C	0.25	3/8-16	2.00	1.31	0.56	0.13	0.75	0.14	0.38	0.38	3.75
SL1116.I50-031-C	0.31	1/2-13	2.00	1.25	0.75	0.15	1.00	0.19	0.50	1.00	5.00
SL1116.I62-038-C	0.38	5/8-11	3.05	2.00	1.00	0.18	1.00	0.19	0.62	1.00	5.00